

Twist 350

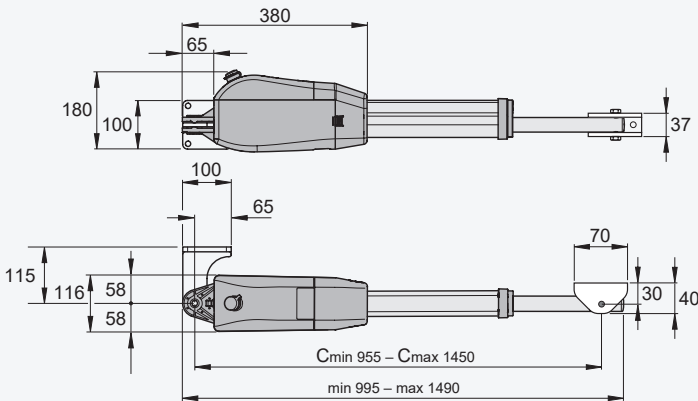

POWERFUL
24V Heavy Duty, Swing Gate Operator

For gates up to 4m **SOMMER** Made in GERMANY



Suited to residential or condominium use



Easily adjustable, in-built limit switches



Bolt on brackets - no welding required



Patent, gear saving brake system that is able to withstand extreme forces



Well suited for heavy gates and/or wind loaded gates



Suitable for solar applications



Automatic locking, prevents the gate from being pushed open manually



Easy to activate manual release function via a key



40% use frequency

Model	Control Board	Motor Power	Max Gate Leaf	Max Stroke	Min Side Room	Max Angle	Travel Speed	Single Kit	Double Kit
Standard Control Box		24V	600kg 4m	450 mm	120mm	120°	15	1656-0073	1656-0074
Standard Control Box + Separate Transformer								1656-0060	1656-0061
Large Control Box								1656-0067	1656-0068
Large Control Box + Separate Transformer								1656-0069	1656-0070

All kits include Twist 350 Operator, Choice of Standard or Large Control Box Kit, 2 x 2 Button Transmitters and 2 Channel Receiver

ENHANCE YOUR TWIST 350

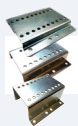

Rear Mounting Brackets:
- 25mm: #5825-0030
- 50mm: #5825-0019
- 100mm: #5825-0020



TorMinal Programming Device - #1018-0096
For programming additional devices



Connecting Cable #5825-0022
12m length



Slide Vibe 4 Button Transmitter #1018-0191
Vibrates & lights when signal is received

POPULAR ACCESSORIES



Telecody+ Keypad
#1018-0124



Wireless Photobeams
#1059-0050



Global Access 24v UPS
#1074-0019



SOMCOM 2 Channel Add-on Receiver
#1018-0094



Tousek Dropbolt
#1045-0030

1300 366 046

sales@global-access.com.au

For more information, visit our website!

global-access.com.au

