

# Mounting and installation manual

## electric drop bolt SAFELOCK with dropbolt control unit



**tousek**<sup>®</sup>  
G A T E   A U T O M A T I O N



Features

- The dropbolt serves the automatic locking of a swing gate. The proper function of the dropbolt is ensured only in a combination with it's control unit and additional module. The dropbolt module must be inserted into the operators control unit..
- The dropbolt module is compatible with the following operator control units: ST51, ST61, ST REX
- emergency release lockable with standard cylinder
- powder coated aluminium housing, stainless steel bolt
- obstacle detection: if the bolt is thwarted, it reverses short and stops
- protection class dropbolt: IP44
- motor control unit protection class: IP54



components of the dropbolt

- (1) bolt with a lift of 125mm (if the lock (2) is released the bolt (with its housing (1a)) is moveable along the mounting rail (3))
- (2) profile half-cylinder with cover cap (2a)
- (3) mounting rail with:
  - (4) Recess for locking by the cylinder lock,
  - (5-7) 3 mounting holes for bolt on the gate with M6 countersunk screw (12)
  - (8) hole for bolt on the connection cable
  - (9) grub screw M4x12 - it serves as bottom limit stop when pushing back the dropbolt into the normal position.



After successful installation the grub screw (9) must be screwed into the bore (9a) at the bottom of the mounting rail as limit stop.

- (10) dropbolt control unit SAFELOCK for one leaf or for double leaf gates.

Packed together:

- (9) grub screw
- (11) 3 keys
- (12) 3 countersunk screws M6

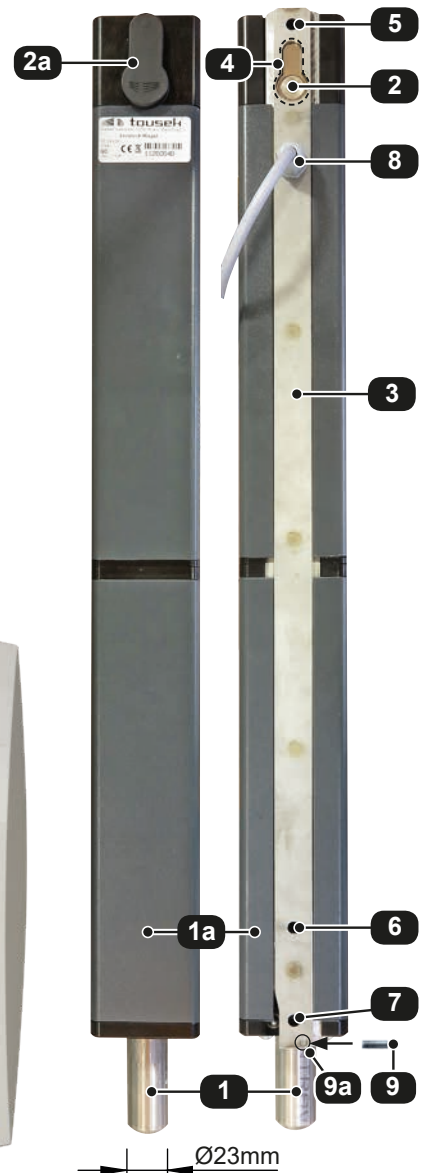
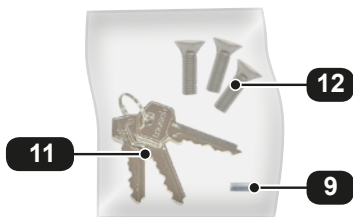

Technical Data

dropbolt SAFELOCK				
Power supply	12-18Vd.c.	Article no.	motor control unit IP54 for 1-leaf	12112150
power consumption	3A		motor control unit IP54 for 2 leaves	12112280
working stroke, diameter	125mm, Ø = 23mm		dropbolt modul (to built in the control unit)	13810240
Lifting force	200N		dropbolt, anthracite grey	11260540
Protection class dropbolt	IP44		dropbolt, grey aluminium	11260590
included in delivery	incl. standard cylinder lock with 3 keys • 1,4m connection cable • grub screw M4x12 • 3x countersunk screws M6			



**Note:** The Safelock can be mounted vertically (**with bolt down!**) or horizontally on the leaf. **When mounting horizontally remove the lower rubber stubble so that moisture can escape.**



- 1 Arrange the mounting height (H): Please note, that the lift of the bolt ist limited by 125 mm (=max. lift of the bolt). The dropbolt is equipped with obstacle detection. If the bolt is thwarted by the bolt seat, then it reverses short and stops.
- 2 Carry out the bore with  $\varnothing 20\text{mm}$  (position 8) on the gate frame according to the mounting height (H). This bore is for the cable outlet. Then supply the 4-pole connection cable to the motor control unit.
- 3 Unlock the SAFELOCK (  see *emergency release, page 4*) and push the housing (1a) up to the limit stop. Now are the bores (6,7) on the mounting rail (3) visible for fixing the SAFELOCK. Exactly at these points on the gate will be the SAFELOCK fixed. Please mind the installation height (H) and the vertical alignment.
- 4 Then push the SAFELOCK along the mounting rail down until limit stop. Now the upper bore (5) for fixing is visible so you can fasten the SAFELOCK.
- 5 If the SAFELOCK is fixed at installation positions (5-7) on the gate then push the SAFELOCK to it's normal position and lock it again. After successful installation the grub screw (9) must be screwed into the bore (9a) at the bottom of the mounting rail (3) as limit stop.

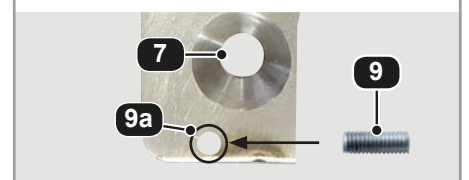
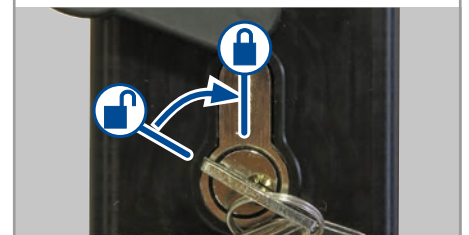
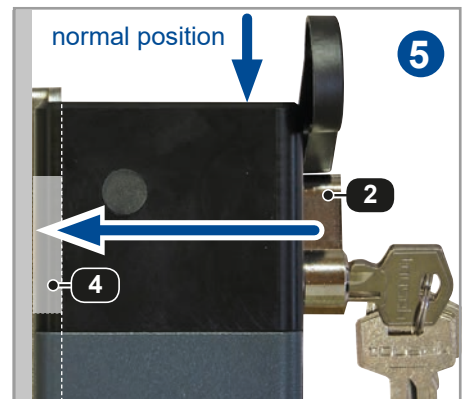
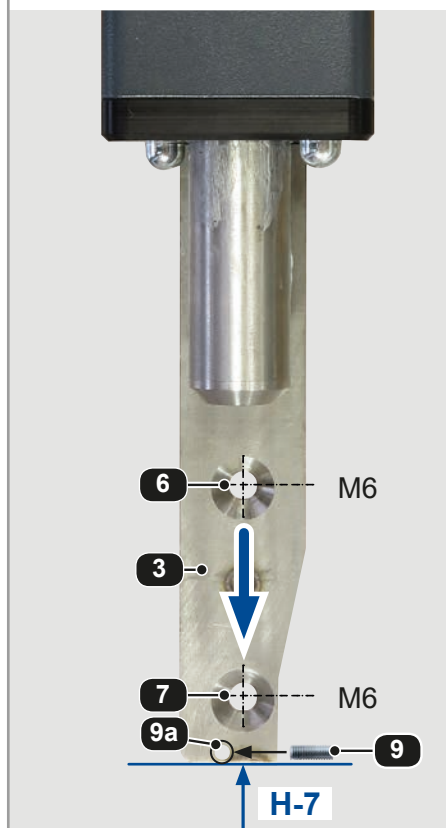
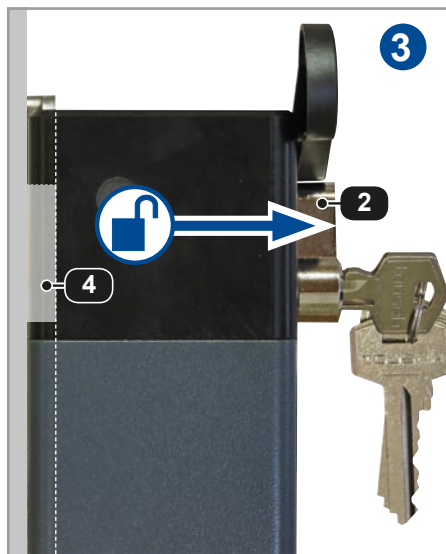
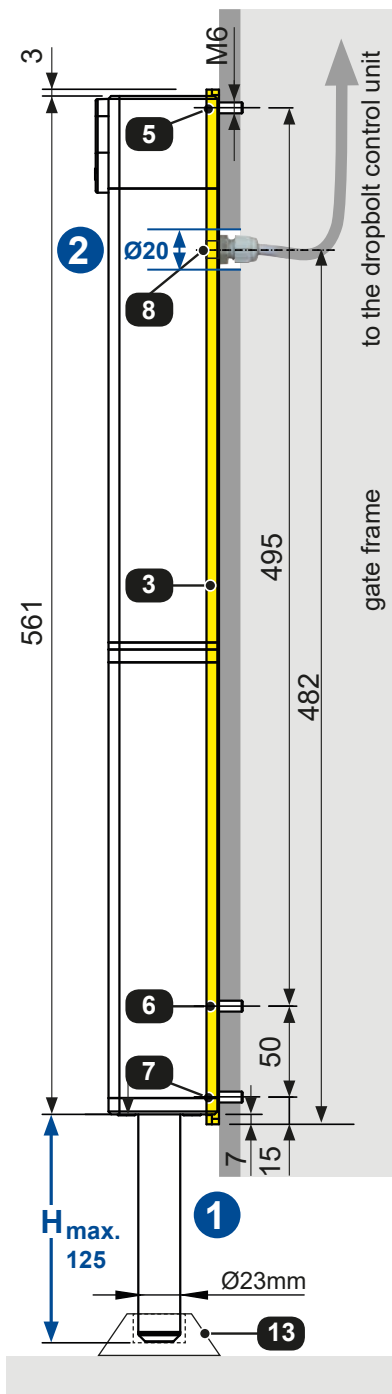

## Emergency release

dropbolt SAFELOCK

The dropbolt can be unlocked as follow:

- **Turn off the power supply.**

1. lift the cover cap of the cylinder (2a) and then twist the cap.
2. insert the key in the lock (2) and turn it to the open position.
3. Now pull the lock forward from the housing as far as it is possible.
4. Now the housing can be pushed up until stop in the mounting rail (3), which is fixed on the gate. So the bolt is lifted out of its lock.

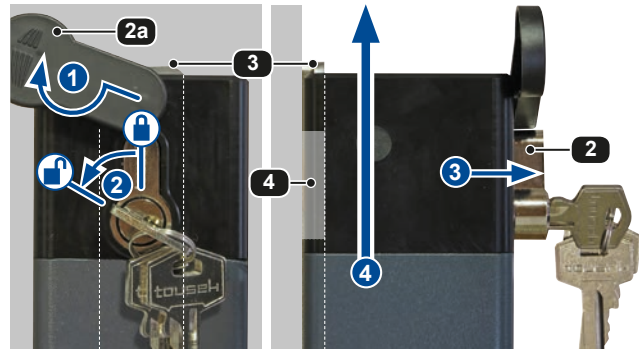

## Locking

- In order to cancel the emergency release push back the housing to its normal position so that the lock (2) by pushing back in the housing goes into the recess (4) of the mounting rail (3).
- Now turn the key into the closed position. After removing the key turn back the cover cap (2a) and turn on the power supply.



## Change of the profile half cylinder

- After removing the rubber protection cap (K) the lock is released and pulled out of the housing until the screw (S) becomes visible in the opening.
- After unscrewing the screw with a hexagon wrench (4,0) the lock can be removed and a new one of the same type can be used.

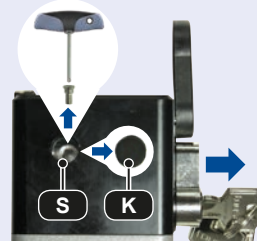

Profile half cylinder (PHC) with 3 keys (Art.n. 13300290)

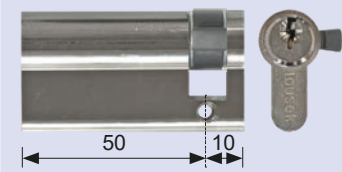

## Connection

### Attention

dropbolt SAFELOCK

- Before cabling works turn off the power supply.
- Be sure that while cabling work the power is still turned off.
- Please note the local safety rules.



## dropbolt module for control unit ST 51, ST 61, REX

- In order to connect the dropbolt SAFELOCK to the control unit it needs an optional modul and a dropbolt control unit. If needed then for double leaf swing gate also two dropbolts can be connected. Thereby the terminal block is labelled with „X“ for the first bolt and with „Y“ for the second bolt.

### Modul connection

- **ATTENTION: Turn off the power supply!**
- Fix the module inside the control unit's housing as shown on the picture. Fix the module on the positions (P1) by spacers and screws (included).
- Connect the modul to the control unit with RJ-plug connection (E).
- Carry out the connections on the modul clamps „X“, „Y“ and on the motor control unit clamps as shown on the picture.
- After successful connection the dropbolt operation need to be activated in the control unit menu („peripherals/locking“ and „peripherals/dropbolt“)

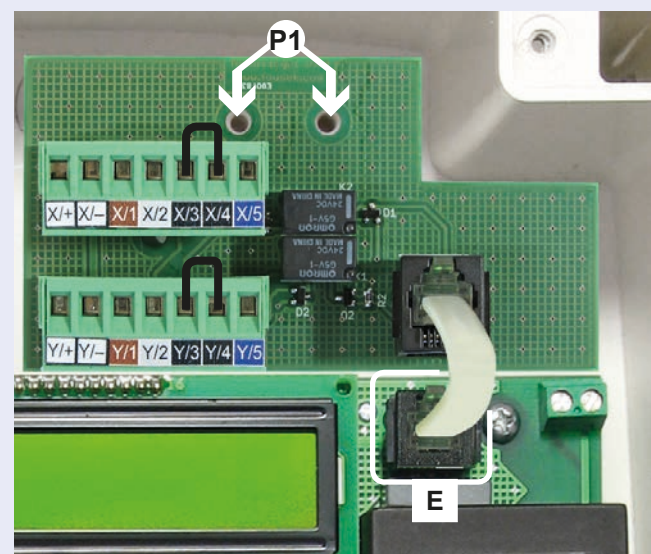

e.g. ST 61 with integrated dropbolt modul



**IMPORTANT: When using only one drop bolt, the wire jumper must remain in the unused terminal block!**



Wire the terminal block (K) of the dropbolt's printed circuit board as shown on the picture::

- on one hand wire it with the module, which is connected to the operator's control unit:
  - for 1 dropbolt: wire only with the terminal block „X“ - for 2 dropbolts wire with terminal blocks „X“+„Y“
- on the other hand wire it with the dropbolt via connection cable 4 x 0,75<sup>2</sup> (motor connection and limit switch) . Strictly note the numbering **1 – 4** of the connection cable's wires for a proper connection.
- Carry out the 230V a.c. power supply connection on terminal block (V) and the earthing connection on the earthing screw.



**SAFELOCK-control unit with 1 motor print:**

- suitable for 1 dropbolt
- connection motor print: with „X“-terminal block

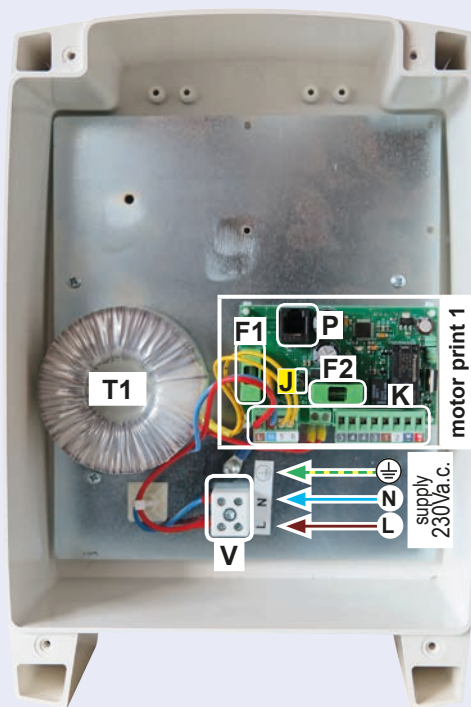

- (P) programming slot
- (F1) fuse 0,25A T
- (F2) fuse 4A T
- (J) Jumper
- (T1) transformer 1
- (T2) transformer 2
- (K) terminals
- (V) 230Va.c. supply terminals

Limit switch closed, if the bolt is retracted

DROPBOLT 1

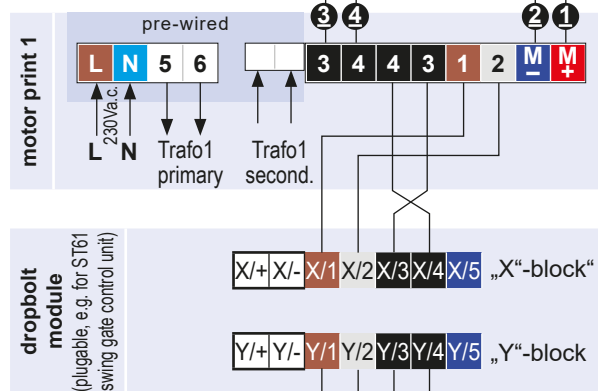
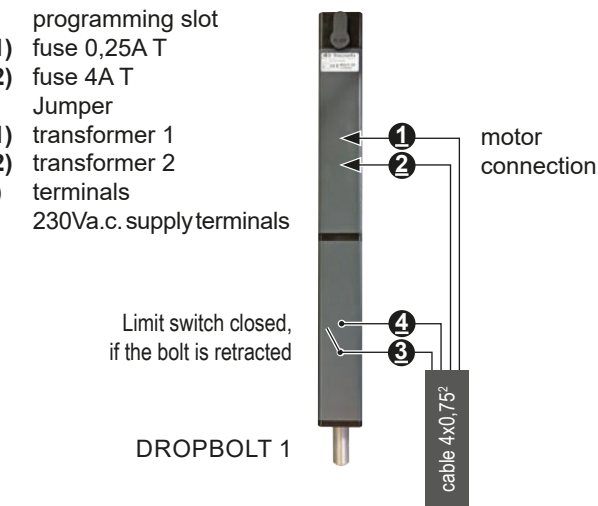

**SAFELOCK-control unit with 2 motor prints:**

- suitable for 2 dropbolts
- connection motor print 1: with „X“-terminal block
- connection motor print 2: with „Y“-terminal block

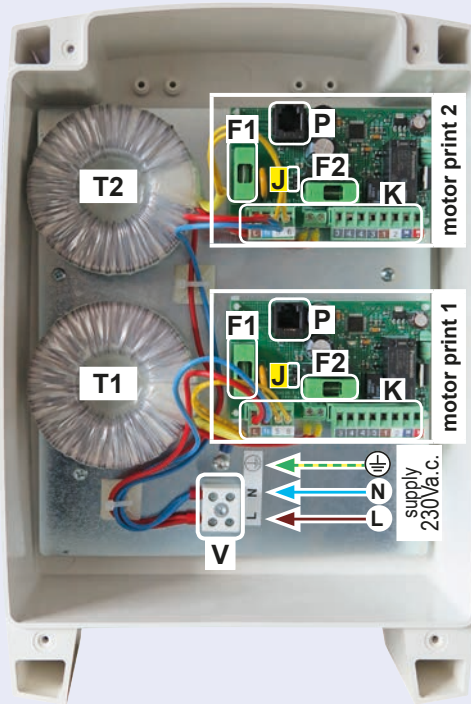

Jumper J	motor print
	„T“ with tousek control units ST 51, ST 61, ST REX
	„T“ with foreign control units

Limit switch closed, if the bolt is retracted

DROPBOLT 2

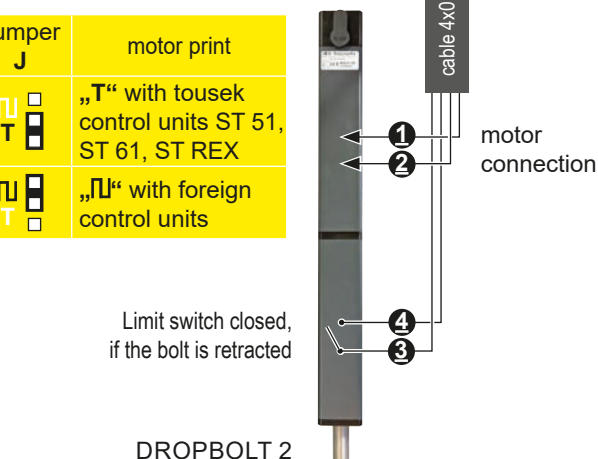

## Use with external (not tousek) control unit

## Connection

- The dropbolt can be used also with external control units. Hereby lapses the additional dropbolt module, which was developed especially for installing into tousek control units.
- Command can be given via potential free switch contact of a relay. This relay must be connected to the clamps 1/2 of the dropbolt control unit's.
- The relay can be switched e.g. via flashlight output of the concerning control unit: with beginning of the pre-warning time switches the relay and the bolt retracts, before the gate movement starts. The bolt extends after the gate movement is completely done.
- **Requirements:**
  - The pre-warning time for opening and closing must take at least 3s in order to retract the bolt completely before the gate movement starts.
  - The relay must be suitable for the voltage of the flashlight output of the external control unit (relay not included).
  - The jumper (**J**) must be used correct (= „□□“).

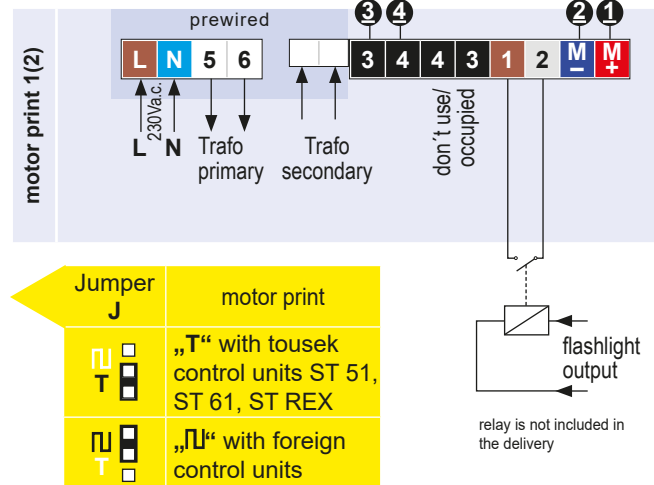
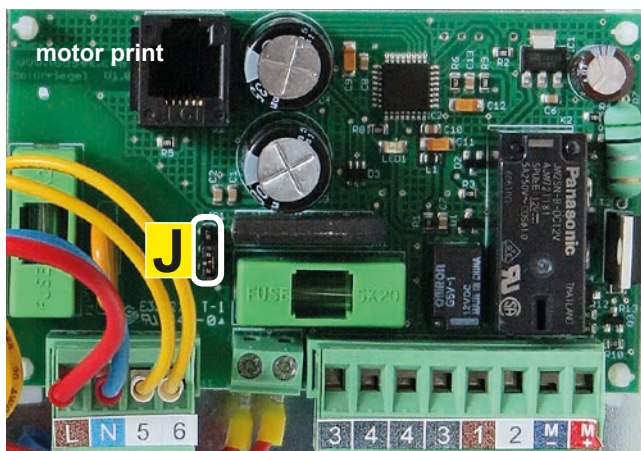

## Motor control unit IP54

## dropbolt SAFELOCK

- dimensions in mm



We reserve the right to change dimensions and technical specifications without prior notice.



## **tousek PRODUCTS**

- sliding gate operators
- cantilever systems
- swing gate operators
- garage door operators
- folding door operators
- traffic barriers
- electronic controls
- radio remote controls
- key operated switches
- access control
- safety devices
- accessories

**Tousek Ges.m.b.H. Austria**  
A-1230 Vienna  
Zetschegasse 1  
Tel. +43/ 1/ 667 36 01  
Fax +43/ 1/ 667 89 23  
info@tousek.at

**Tousek GmbH Germany**  
D-83395 Freilassing  
Traunsteiner Straße 12  
Tel. +49/ 8654/ 77 66-0  
Fax +49/ 8654/ 57 196  
info@tousek.de

**Tousek Benelux NV**  
BE-3930 Hamont - Achel  
Buitenheide 2A/ 1  
Tel. +32/ 11/ 91 61 60  
Fax +32/ 11/ 96 87 05  
info@tousek.nl

**Tousek Sp. z o.o. Poland**  
PL 43-190 Mikołów (k/Katowic)  
Gliwicka 67  
Tel. +48/ 32/ 738 53 65  
Fax +48/ 32/ 738 53 66  
info@tousek.pl

**Tousek s.r.o. Czech Republic**  
CZ-252 61 Jeneč u Prahy  
Průmyslová 499  
Tel. +420 / 777 751 730  
info@tousek.cz

**tousek**  
E\_SAFELOCK\_01  
07. 10. 2019



**tousek**<sup>®</sup>  
G A T E A U T O M A T I O N

*your service partner:*

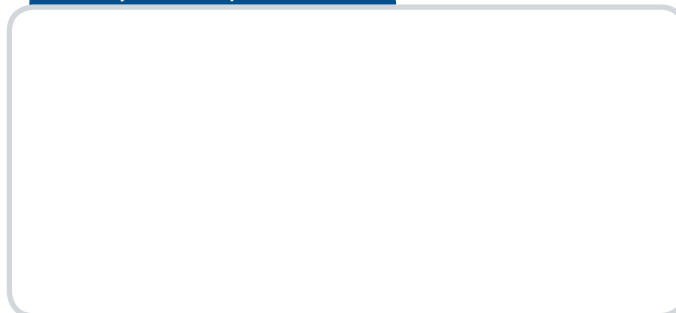

We reserve the right to change dimensions and/or technical specifications without prior notice. Claims resulting from misprints or errors cannot be accepted.

