

# Twist 350



**POWERFUL**  
24V Heavy Duty, Swing Gate Operator

For gates up to 4m



Made in GERMANY

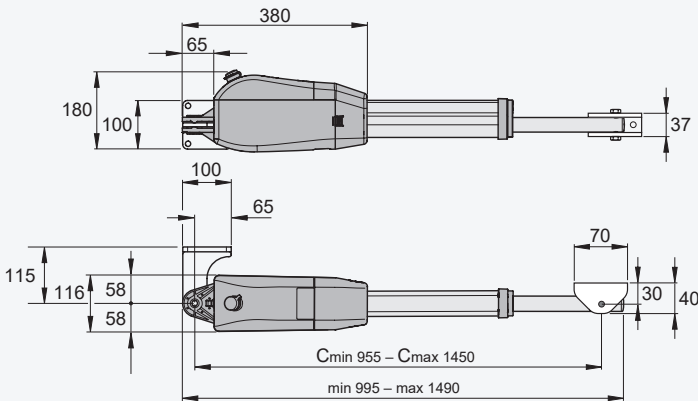

Suited to residential or condominium use



Easily adjustable, in-built limit switches



Bolt on brackets - no welding required



Patent, gear saving brake system that is able to withstand extreme forces



Well suited for heavy gates and/or wind loaded gates



Suitable for solar applications



Automatic locking, prevents the gate from being pushed open manually



Easy to activate manual release function via a key



40% use frequency

Model	Control Board	Motor Power	Max Gate Leaf	Max Stroke	Min Side Room	Max Angle	Force (NM)	Single Kit	Double Kit
Standard Control Box		24V	250kg @4m 600kg @2m	450 mm	120mm	120°	2500	1656-0073	1656-0074
Standard Control Box + Separate Transformer								1656-0060	1656-0061
Large Control Box								1656-0067	1656-0068
Large Control Box + Separate Transformer								1656-0069	1656-0070

All kits include Twist 350 Operator, Choice of Standard or Large Control Box Kit, 2 x 2 Button Transmitters and 2 Channel Receiver

## ENHANCE YOUR TWIST 350

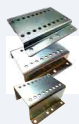

**Rear Mounting Brackets:**  
- 25mm: #5825-0030  
- 50mm: #5825-0019  
- 100mm: #5825-0020



**TorMinal Programming Device - #1018-0096**  
For programming additional devices



**Connecting Cable #5825-0022**  
12m length



**Slide Vibe 4 Button Transmitter #1018-0191**  
Vibrates & lights when signal is received

## POPULAR ACCESSORIES



**Telecody+ Keypad**  
#1018-0124



**Wireless Photobeams**  
#1059-0050



**Global Access 24v UPS**  
#1074-0019



**SOMCOM 2 Channel Add-on Receiver**  
#1018-0094



**Tousek Dropbolt**  
#1045-0030

1300 366 046

sales@global-access.com.au

For more information, visit our website!

[global-access.com.au](http://global-access.com.au)

