

# SP 900

## 24V SLIDING GATE OPERATOR

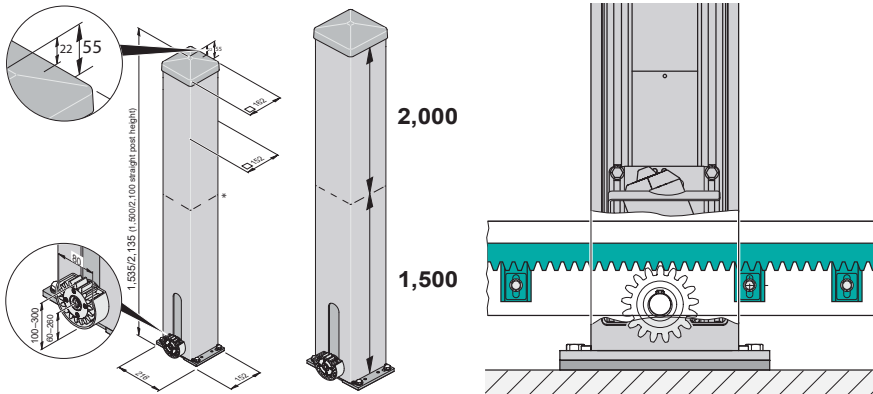

Made in GERMANY



Seamless in-post design, with a sophisticated drive mechanism fully enclosed in the pillar



Robust, aluminium build



Optional Backup Battery provides emergency egress



Automatic locking counteracts forces during break in attempts



Soft open and close offering smooth operation & longevity



Eco-friendly, offering low electricity consumption



Partial opening options for controlled entry



Intelligent, self-learning control board (DPS)



Easy to operate manual release



High speed, magnetic limit switches



Excellent for Solar applications

	Motor Power	Rec Gate Leaf	Duty Cycle	Pinion Height	Part Number
<b>SP 900</b>	24V	350Kg @ 285mm/sec	40%	Adj. up to 40 mm	1516-0034

SP900 2100mm Aluminium Operator unit, Integrated Control Unit, Mounting Plate, Leveling Plate, 2 channel receiver and 2x 2 button transmitters

### POPULAR ACCESSORIES



**Backup Battery with Cable**  
Offers emergency egress  
#5106-0024



**Standard Rack**  
Standard [N6] Nylon Rack, 6 Lugs Down, with steel insert  
#1053-0006



**Torminal**  
Programming device that adjusts various parameters & settings  
#1018-0131

1300 366 046

sales@global-access.com.au

For more information, visit our website!

[global-access.com.au](http://global-access.com.au)

