

# S800H

24V UNDERGROUND HYDRAULIC OPERATOR

**FAAC**  
Simply automatic.

 Made in ITALY

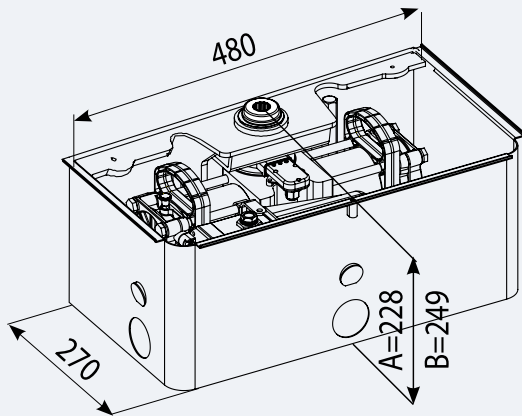

Optional - stainless steel foundation box

#6049-0184

**GLOBAL**  
ACCESS



Suited to residential and condominium use



In-ground operator, offering seamless integration



Built-in stops (opening angle 100° or 180°)



Integrated '2EASY' BUS Magnetic Encoder



Optional upgrade - stainless steel foundation box



Lever operated release key - optional hydraulic release



Solar options available



Welding required for installation



Advanced E124 Control Board



100% use frequency



Integrated handles, adding ease to installation

Model	Motor Power	Max Gate Leaf	Max Gate Length	Wind Load Rating	Stroke	Part Number
S800 Single Kit 100°	24V	350kg	2m	7/10	Up to 180°	1656-0030
S800 Double Kit 100°						1656-0029
S800 Single Kit 180°						1656-0032
S800 Double Kit 180°						1656-0031

All kits include S800 Underground Operator with E124 Board, 2 x Transmitters, Receiver, Absolute Encoder and High Powered Aerial

## POPULAR ACCESSORIES



**Hydraulic Manual Release**  
S800 Hydraulic Manual Release (collar assembly required)  
#6049-0174



**XP20 Wireless Photo Beams**  
Pair of FAAC wireless Photo Beams for vehicle safety  
#1059-0011



**Range Increasing Antenna**  
433MHz Aerial with bracket & 5m or Coax Cable  
#6049-0326

☎ 1300 366 046

✉ sales@global-access.com.au

For more information, visit our website!

[global-access.com.au](http://global-access.com.au)

