

# E124

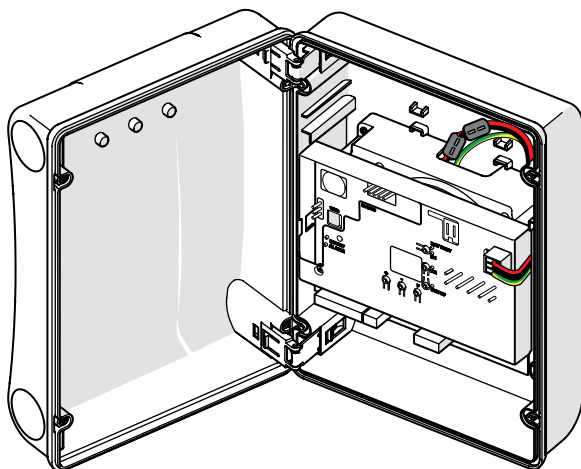

# FAAC

Translation of the original instructions



FAAC S.p.A. Soc. Unipersonale  
Via Calari, 10 - 40069 Zola Predosa BOLOGNA - ITALY  
Tel. +39 051 61724 - Fax +39 051 09 57 820  
www.faac.it - www.faacgroup.com

© Copyright FAAC S.p.A. dal 2020. Tutti i diritti riservati.

Nessuna parte di questo manuale può essere riprodotta, archiviata, distribuita a terzi né altrimenti copiata, in qualsiasi formato e con qualsiasi mezzo, sia esso elettronico, meccanico o tramite fotocopia, senza il preventivo consenso scritto di FAAC S.p.A.

Tutti i nomi e i marchi citati sono di proprietà dei rispettivi fabbricanti.

I clienti possono effettuare copie per esclusivo utilizzo proprio.

Questo manuale è stato pubblicato nel 2020.

© Copyright FAAC S.p.A. from 2020. All rights reserved.

No part of this manual may be reproduced, archived, distributed to third parties nor copied in any other way, in any format and with any means, be it electronic, mechanical or by photocopying, without prior written authorisation by FAAC S.p.A.

All names and trademarks mentioned are the property of their respective manufacturers.

Customers may make copies exclusively for their own use.

This manual was published in 2020.

© Copyright FAAC S.p.A. depuis 2020. Tous droits réservés.

Aucune partie de ce manuel ne peut être reproduite, archivée ou distribuée à des tiers ni copiée, sous tout format et avec tout moyen, qu'il soit électronique, mécanique ou par photocopie, sans le consentement écrit préalable de FAAC S.p.A.

Tous les noms et les marques cités sont la propriété de leurs fabricants respectifs.

Les clients peuvent faire des copies pour leur usage exclusif.

Ce manuel a été publié en 2020.

© Copyright FAAC S.p.A. ab dem 2020. Alle Rechte vorbehalten.

Kein Teil dieses Handbuchs darf reproduziert, gespeichert, an Dritte weitergegeben oder sonst auf eine beliebige Art in einem beliebigen Format und mit beliebigen Mitteln kopiert werden, weder mit elektronischen, noch mechanischen oder durch Fotokopieren, ohne die Genehmigung von FAAC S.p.A. Alle erwähnten Namen und Marken sind Eigentum der jeweiligen Hersteller. Die Kunden dürfen nur für den Eigengebrauch Kopien anfertigen.

Dieses Handbuch wurde 2020 veröffentlicht.

© Copyright FAAC S.p.A. del 2020. Todos los derechos están reservados.

No puede reproducirse, archivar, distribuirse a terceros ni copiarse de ningún modo, ninguna parte de este manual, con medios mecánicos o mediante fotocopia, sin el permiso previo por escrito de FAAC S.p.A.

Todos los nombres y las marcas citadas son de propiedad de los respectivos fabricantes.

Los clientes pueden realizar copias para su uso exclusivo.

Este manual se ha publicado en 2020.

© Copyright FAAC S.p.A. van 2020. Alle rechten voorbehouden.

Niets uit deze handleiding mag gereproduceerd, gearchiveerd, aan derden openbaar gemaakt of op andere wijze gekopieerd worden, in om het even welke vorm en met geen enkel middel, noch elektronisch, mechanisch of via fotokopiëren, zonder schriftelijke toestemming vooraf van FAAC S.p.A. Alle vermelde namen en merken zijn eigendom van de respectievelijke fabrikanten.

De klanten mogen kopieën maken die enkel voor eigen gebruik bestemd zijn.

De handleiding werd in 2020 gepubliceerd.

**CONTENTS**

EU Declaration of conformity ..... 2

**1. INTRODUCTION TO THE INSTRUCTION MANUAL** ..... **3**

    Meaning of the symbols used ..... 2

**2. SAFETY RECOMMENDATIONS** ..... **4**

    Installer safety ..... 4

    Transport and storage ..... 4

    Disposal of the product ..... 4

**3. E124** ..... **5**

    3.1 Intended use ..... 5

    3.2 Limitations of use ..... 5

    3.3 Unauthorised use ..... 5

    3.4 Product identification ..... 5

    3.5 Technical characteristics ..... 6

**4. INSTALLATION REQUIREMENTS** ..... **7**

    Electrical system ..... 7

    Overall dimensions of the enclosure ..... 7

**5. INSTALLATION** ..... **8**

    Tools required ..... 8

    5.1 Install the enclosure ..... 8

        Remove the cover ..... 8

        Prepare the cable routing holes ..... 8

        Fasten the enclosure ..... 9

        Install the cover ..... 9

    5.2 Components ..... 10

        Switching power supply ..... 10

        Board E124 ..... 11

    5.3 Connections ..... 12

        BUS 2easy (2EASY) devices ..... 12

        Control devices (IN) ..... 12

        Limit switch (FC) ..... 12

        Gatecoder (ENC) ..... 13

        Configurable outputs (OUT1, OUT2) ..... 13

        Flashing light 24 V  $\equiv$  (LAMP) ..... 13

        Electric lock (LOCK/ OUT1, OUT2) ..... 13

        Motor 1 (MOT1) ..... 13

        Motor 2 (MOT2) ..... 13

        XF MODULE ..... 14

        Radio receiver/decoder board ..... 14

        Emergency batteries (BATTERY) ..... 14

        Mains power supply (CON) ..... 14

**6. START-UP** ..... **15**

    Set-up procedure ..... 15

    6.1 Turn power on to the board ..... 15

    6.2 Programming the board ..... 15

    6.3 SETUP ..... 21

    6.4 Configuring movements and timing ..... 22

    6.5 Adjusting the anti-crushing system ..... 22

    6.6 Final checks ..... 23

    6.7 Close the enclosure ..... 23

**7. ACCESSORIES** ..... **24**

    7.1 BUS 2easy devices ..... 24

    BUS 2easy control devices ..... 24

    BUS 2easy Photocells, Sensitive edges ..... 25

    BUS 2easy encoder ..... 26

    7.2 Registering/Removing BUS 2easy devices ..... 26

    7.3 Relay photocells ..... 27

        Functional test (Fail-Safe) ..... 27

    7.4 Radio controls - SLH/SLHLR ..... 28

        Memorising the master on the board ..... 28

        Adding radio controls ..... 28

    7.5 Radio controls - RC/LC ..... 29

        Memorising the radio controls on the board ..... 29

        Adding radio controls ..... 29

    7.6 Radio controls - DS ..... 30

        Memorising radio controls on the board ..... 30

    7.7 Deleting all radio controls ..... 30

    7.8 Simply Connect ..... 31

    7.9 Emergency batteries ..... 32

    7.10 External power supply ..... 32

**8. DIAGNOSTICS** ..... **33**

    Signalling LEDs on the board ..... 33

    Firmware version (FW) ..... 34

    Status of the automation ..... 34

    Checking the movement ..... 34

    BUS 2easy status ..... 34

    Warnings from a programmable output ..... 34

    Error codes, Alarms/Info ..... 35

    RESET ..... 36

**9. MAINTENANCE** ..... **37**

    9.1 Routine maintenance ..... 37

        Cycle counter ..... 38

        Maintenance requested ..... 38

    9.2 Restoring factory settings ..... 38

**10. OPERATION** ..... **39**

    Commands ..... 39

    Battery operation (if present) ..... 39

    Detection devices ..... 39

    Accessories ..... 39

    Operating logics ..... 39

**TABLES**

 **1** Technical data ..... 6

 **2** Basic programming menu ..... 16

 **3** Advanced programming menu ..... 18

 **4** SETUP phases ..... 21

 **5** BUS 2easy command DIP switches ..... 24

 **6** BUS 2easy photocells and sensitive edges DIP switches ..... 25

 **7** Automated system status ..... 34

 **8** Errors, Alarms, Info ..... 35

 **9** Scheduled maintenance ..... 37

**EU DECLARATION OF CONFORMITY**

The Manufacturer

**Company name:** FAAC S.p.A. Soc. Unipersonale  
**Address:** Via Calari, 10 - 40069 Zola Predosa BOLOGNA - ITALY

hereby declares under its own exclusive liability that the following product:

**Description:** Electronic equipment  
**Model:** E124

complies with the following applicable EU legislations:  
 2014/30/EU, 2014/35/EU, 2011/65/EU

Furthermore, the following harmonised standards have been applied:  
 EN 61000-6-2:2005, EN 61000-6-3:2007+A1:2011  
 EN 60335-1:2012+A11:2014+A13:2017, EN 60335-2-103:2015

Other standards applied: EN 13849-1:2015 CAT.2 PL "C", EN 13849-2:2012

Bologna, 01-08-2020  
 CEO  
 A. Marcellan



ENGLISH

Translation of the original instructions

**1. INTRODUCTION TO THE INSTRUCTION MANUAL**

This manual provides the correct procedures and requirements for installing E124 and maintaining it in a safe condition.

When drafting the manual, the results of the risk assessment conducted by FAAC S.p.A. on the entire product life cycle have been taken into account in order to implement effective risk reduction measures. The following stages of the life cycle of the product have been considered:

- Delivery/handling
- Assembly and installation
- Set-up and commissioning
- Operation
- Maintenance/troubleshooting
- Disposal at the end of the product's life cycle

Risks arising from installation and using the product have been taken into consideration; these include:

- Risks for the installation/maintenance technician (technical personnel)
- Risks for the user of the automation system
- Risks to product integrity (damage)

In Europe, the automation of a gate falls under the Machinery Directive 2006/42/EC and the corresponding harmonised standards. Anyone automating a gate (new or existing) is classified as the Manufacturer of the Machine. They are therefore required by law, among other things, to carry out a risk analysis of the machine (automatic gate in its entirety) and take protective measures to fulfil the essential safety requirements

specified in Annex I of the Machinery Directive.

FAAC S.p.A. recommends that you always comply with the EN 12453 standard and in particular that you adopt the safety criteria and devices indicated, without exception, including the dead-man function.

This manual also contains general information and guidelines, which are purely illustrative and not exhaustive, in order to facilitate the activities carried out by the Manufacturer of the Machine in all respects with regard to carrying out the risk analysis and drafting the instructions for use and maintenance of the machine. It should be clearly understood that FAAC S.p.A. accepts no liability for the reliability and/ or completeness of the above instructions. As such, the manufacturer of the machine must carry out all the activities required by the Machinery Directive and the corresponding harmonised standards on the basis of the actual condition of the locations and structures where the product E124 will be installed, prior to commissioning the machine. These activities include the analysis of all the risks associated with the machine and subsequent implementation of all safety measures intended to fulfil the essential safety requirements.

This manual contains references to European standards. The automation of a gate must fully comply with any laws, standards and regulations applicable in the country where installation will take place.



Unless otherwise specified, the measurements provided in the instructions are in mm.



**MEANING OF THE SYMBOLS USED**

**NOTES AND WARNINGS IN THE INSTRUCTIONS**



**WARNING ELECTRIC SHOCK HAZARD** - The operation or step described must be carried out following the instructions provided and according to the safety regulations.



**WARNING, personal injury hazard or risk of damage to components** - The operation or stage described must be performed following the supplied instructions and applicable safety regulations



**WARNING** - Details and specifications which must be respected in order to ensure that the system operates correctly.



**RECYCLING AND DISPOSAL** - The materials used in manufacturing, the batteries and any electronic components must not be sent to landfill. They must be taken to authorised recycling and disposal centres.



**FIGURE** E.g.: 1-3 see Figure 1 - item 3.



**TABLE** E.g.: 1 see Table 1.

§ CHAPTER/SECTION E.g. §1.1 see Section 1.1.

○ LED off

● LED on

\* LED flashing

\* LED flashing quickly

**SAFETY SIGNS AND SYMBOLS (EN ISO 7010)**



**GENERAL HAZARD** Risk of personal injury or damage to the parts.



**RISK OF ELECTRIC SHOCK** Risk of electric shock from live parts.



**SPENT BATTERY HAZARD** Risk to the environment and health posed by batteries at the end of their lives due to fluid escaping.



**EXPLOSION HAZARD** Risk of explosion due to gas produced by lead batteries building up inside the container (OPTIONAL).

**PERSONAL PROTECTIVE EQUIPMENT**



Obligation to wear work gloves.



Obligation to wear safety footwear.

**MARKINGS ON PACKAGING**



Handle with care. Presence of fragile parts.



This way up: DO NOT turn over.



Store away from water and humidity.



CE marking.



**RECYCLE and DISPOSE** of at authorised waste collection centres.

**TOOLS (type and size)**



**FLAT-HEAD SCREWDRIVER** of the specified size (6, 8...) 6-8...



**CROSS-HEAD SCREWDRIVER** of the specified size (6, 8...) 6-8...



**ELECTRICIAN'S SCISSORS**



**WIRE STRIPPERS**

## 2. SAFETY RECOMMENDATIONS

This product has been placed on the market as a control system for actuators for swinging gates, therefore must not be commissioned until the machine in which it has been incorporated has been identified and declared to conform to the Machinery Directive 2006/42/EC by the actual Manufacturer.



Incorrect installation and/or incorrect use of the product might cause serious harm to people. Read and comply with all the instructions before starting any activity on the product. Keep these instructions for future reference.

Perform installation and other activities adhering to the sequences provided in the instructions manual.

Always comply with all the requirements contained in the instructions and warning tables at the beginning of the paragraphs. Always comply with the safety recommendations.

Only the installer and/or maintenance technician is authorised to work on the automation components. Do not modify the original components in any way.

Close off the work site (even temporarily) and prevent access/transit. EC countries must comply with the legislation that transposes the European Construction Site Directive 92/57/EC.

The installer is responsible for the installation/testing of the automation and for completing the Register of the system.

The installer must prove or declare to possess technical and professional proficiency to perform installation, testing and maintenance activities according to the requirements in these instructions.

### INSTALLER SAFETY

Installation activities require special work conditions to reduce to the minimum the risks of accidents and serious damage. Furthermore, the suitable precautions must be taken to prevent risks of injury to persons or damage.



The installer must be in good physical and mental condition, aware of and responsible for the hazards that may be generated when using the product.

The work area must be kept tidy and must not be left unattended.

Do not wear clothes or accessories (scarves, bracelets, etc.) that may get caught in moving parts.

Always wear the personal protective equipment recommended for the type of activity to be carried out.

The required level of workplace lighting must be equal to at least 200 lux.

Operate CE marked machinery and equipment in compli-

ance with the manufacturer's instructions. Use work instruments in good conditions.

Use the transport and lifting equipment recommended in the instructions manual.

Use safety-compliant portable ladders of adequate size, fitted with anti-slip devices at the top and bottom, equipped with retainer hooks.

### TRANSPORT AND STORAGE

Store the product in its original packaging, in closed and dry premises, protected from the sun and free from dust and aggressive substances. Protect from mechanical stress. If stored for more than 3 months, regularly check the condition of the components and the packaging.

- Storage temperature: 5°C to 30°C.
- Percentage of humidity: 30% to 70%.

### DISPOSAL OF THE PRODUCT



The packaging materials (plastic, polystyrene etc.) must not be left within reach of children as they are potential sources of danger.

Discard the packaging after use in the appropriate containers in compliance with waste disposal regulations.

After having dismantled the product, dispose of it in compliance with the current waste disposal regulations.



Components and structural materials, batteries and electronic components must not be disposed of together with household waste. They must be taken to authorised disposal and recycling centres.

### 3. E124

#### 3.1 INTENDED USE

The E124 electronic board has been designed to control one or two 24 V  $\overline{\text{=}}$  actuators with brushed motors having a maximum power of 70 W, for motorized horizontal movement swing gates intended for installation in areas that are accessible to people. Their main purpose is to provide safe access for goods or vehicles accompanied or driven by people in industrial, commercial or residential settings.

 Risks arising from installation and use of the product and accessory devices have not been evaluated for motors not manufactured by FAAC.

Any other use that is not expressly specified in these instructions is prohibited and could affect the integrity of the product and/or represent a source of danger.

#### 3.2 LIMITATIONS OF USE

- Do not use with motors where the technical data shown on the rating plate are outside the limits indicated in board instruction manual.
- Using the product in any configuration other than that intended by FAAC S.p.A. is prohibited. It is prohibited to modify any of the product's components. Do not install the board unless it is housed in the enclosure supplied by FAAC.

#### 3.3 UNAUTHORISED USE

- Do not use on motors or devices that are intended for purposes other than operating gates.
- Uses other than the intended use are prohibited.
- It is prohibited to install the E124 on smoke and/or fire doors.
- It is prohibited to install the E124 in environments in which there is a risk of explosion and/or fire: the presence of flammable gases or fumes is a serious safety hazard (the product is not ATEX certified).
- It is prohibited to power the system with energy sources other than those specified.
- It is prohibited to integrate commercial systems and/or equipment other than those specified, or use them for purposes not envisaged and authorised by the corresponding manufacturers.
- It is prohibited to use and/or install accessories which have not been specifically authorised by FAAC S.p.A.
- It is prohibited to use the E124 in the presence of faults which could compromise safety.
- Do not allow water jets of any type or size to come into direct contact with the E124.

- Do not expose the E124 to corrosive chemical or environmental agents.

#### 3.4 PRODUCT IDENTIFICATION

The board is identified by the label (see  figure).

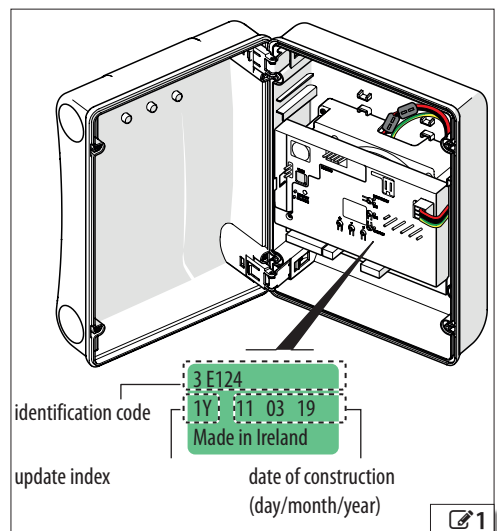

## 3.5 TECHNICAL CHARACTERISTICS

### 1 Technical data

Power supply voltage	198...264/104...126 V~ 50/60 Hz
Max power	200 W (4 W in stand-by)
Max. power of each motor	70 W
Max. accessories load	24 V=== 500 mA
Max. BUS 2easy accessories load	500 mA
Max. flashing light load	24 V=== 15 W
IP	IP54
Ambient operating temperature	-20 ... +55°C

The E124 can control one or two 24 V === brushed motors, each having a maximum power of 70 W.

**Enclosure** the enclosure houses the E124 and the switching power supply and is designed to house the emergency battery (optional).

**Board cover** The cover protects against electric shock by contact with live parts of the circuit.

**Switching power supply with 230/115 V ~ voltage selector (factory set to 230 V ~)** The switching power supply reduces power consumption in stand-by, keeps the output voltage stable even in the event of fluctuations in the mains supply and works over a wide range of input voltages.

**Secondary power supply 24V ===** If there is no mains power, rechargeable emergency batteries can be used (the charger is integrated in the board) or solar panels.

**BUS 2easy** E124 allows you to connect control and detection devices from the FAAC BUS 2easy range (pulse generators, encoders, photocells...). In addition, traditional devices (photocells, sensitive edges) with an NC contact can be used.

**i** BUS 2easy control devices require E124 firmware version **FW 3.2** or later.

**Adjustable sensitivity obstacle detection** An obstacle that prevents the leaf from moving can be detected by monitoring the current absorbed by the motor or using an encoder (if present).

**Encoder** An accessory encoder can be used (e.g. SAFEncoder BUS 2easy or Gatecoder) or one integrated in the actuator (S800H ENC). The electronic board detects the angular position and the speed of movement of the leaf via the encoder and is able to detect the presence of an obstacle.

**Adjustable slowdown speed.**

**2 programmable outputs.**

**Radio System** The E124 is fitted with an integrated two channel decoding system OmniDEC, for the OPEN A command on channel 1 (total motion) and the OPEN

B command on channel 2 (partial motion). Alternatively, channel 2 OMNIDEC can be enabled to activate a programmable output. The XF (3 pin) plug-in type accessory module allows various types of FAAC radio codes to be memorised: SLH/SLH LR, LC/RC, DS. The various types of radio codes can coexist as long as the radio controls have the same frequency.

In addition, a quick insertion (5 pin) connector for FAAC radio/decoder boards is available.

**Diagnostics** using LEDs, display and Simply Connect notifications (optional).

**Programming** There are two menus for programming from the board, via display and dedicated buttons: BASIC and ADVANCED.

In addition, remote programming from Simply Connect provides a larger number of options, including uploading / downloading the programming and updating the board FW.

**Simply Connect** This CLOUD platform allows remote communication with the automation, with modes specific for the installer or user. Simply Connect requires an accessory connectivity module to be plugged in, which is chosen according to technology used:

- XMB (GSM for mobile, Bluetooth Low Energy technology)
- XWBL (WiFi, LAN, Bluetooth Low Energy technology).

**i** Simply Connect requires E124 firmware version **FW 4.0** or later.

## 4. INSTALLATION REQUIREMENTS

### ELECTRICAL SYSTEM



Always shut off the power supply before performing any work. If the disconnect switch is not in view, apply a warning sign stating "WARNING - Maintenance in Progress".



The electrical system must comply with applicable legislation in the country of installation.

Use components and materials with CE marking which are compliant with the Low Voltage Directive 2014/35/EU and EMC Directive 2014/30/EU.

The power supply line for the automation must be fitted with a multi-pole circuit breaker, with a suitable tripping threshold, a contact opening distance of at least 3 mm and a breaking capacity that complies with current regulations.

The power supply for the automation must be fitted with a 30 mA differential switch.

The metal parts of the structure must be earthed.

Check that the protective earthing system complies with applicable regulations in the country of installation.

The electrical cables of the automation system must be of a size and insulation class that is compliant with current legislation and laid in appropriate rigid or flexible conduits, either above or below ground.

Use separate conduits for the power supply and the 12-24 V control devices / accessories cables.

Check buried cable plans to ensure that there are no other electrical cables in proximity to the planned digging/drilling locations to prevent the risk of electrocution.

Check that there are no pipes in the vicinity as well.

The external electronic board must be housed in an enclosure that has a minimum IP 44 protection rating and fitted with a lock or another type of device to prevent access by unauthorised persons. The enclosure must be located in an accessible and non-hazardous area and at least 30 cm from the ground. The cable outlets must face downwards.

The conduit fittings and the cable glands must prevent the entry of moisture, insects and small animals.

Protect extension connections using junction boxes with an IP 67 protection rating or higher.

The overall length of the BUS cables must not exceed 100 m.

It is recommended to install a flashing light in a visible position to indicate when it is moving.

The control accessories must be positioned in areas that are always accessible and not dangerous for the user. It is recommended to position the control accessories within the field of view of the automation. This is mandatory in the case of hold-to-run controls.

The hold-to-run controls in the dead-man mode of operation, must comply with standard EN 60947-5-1.

If an emergency stop button has been installed, it must be EN13850 compliant.

Comply with the following heights from the ground:

- control accessories = minimum 150 cm
- emergency buttons = maximum 120 cm

If the manual controls are intended to be used by disabled or infirm persons, highlight them with suitable pictograms and make sure that these users are able to access them.

### OVERALL DIMENSIONS OF THE ENCLOSURE

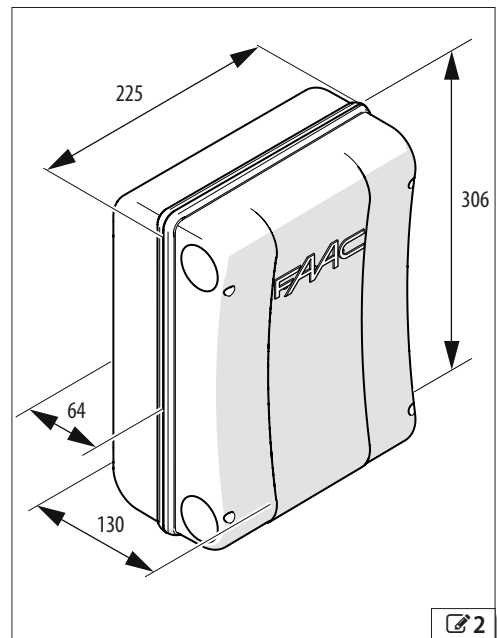

## 5. INSTALLATION

### RISKS



### PERSONAL PROTECTIVE EQUIPMENT



**⚡** CARRY OUT THE WORK WITH THE ELECTRICAL POWER SUPPLY DISCONNECTED.

If the power disconnect switch is not in view, place a “WARNING - Maintenance in Progress” sign on it.

Turn the power on only after having made all the electrical connections and carried out the preliminary start-up checks.

Never remove the board cover unless the instructions specifically indicate that you should do so.

**!** Handle the enclosure carefully so as not to damage the board and the components.

### TOOLS REQUIRED



### 5.1 INSTALL THE ENCLOSURE

#### REMOVE THE COVER

**3** To release the hinges, press on the catch of each hinge and then remove them.

#### PREPARE THE CABLE ROUTING HOLES

**4** Open the cable routing holes to a diameter suitable for the diameter of the conduits. Install suitable cable glands.

Remove the cover

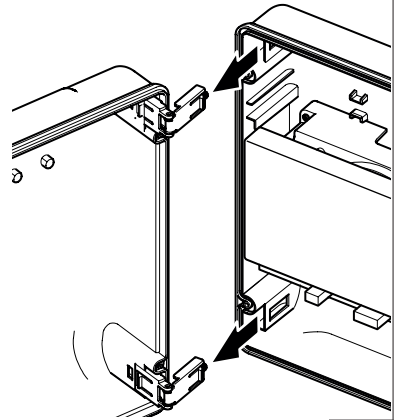
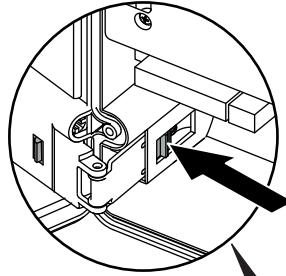

Prepare the cable routing holes

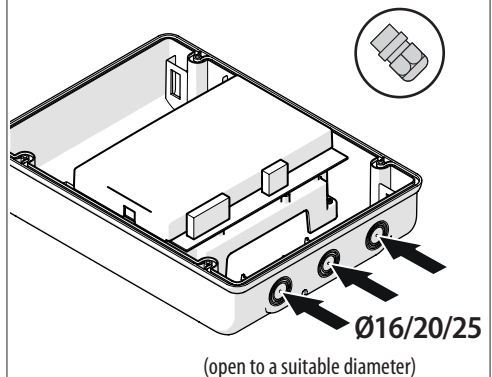

**FASTEN THE ENCLOSURE**

1. (✍️ 5) Remove the 4 screw caps (Ø 5 mm holes).
2. Mark the fixing points on the support, drill the holes and secure using suitable screws and dowels, lastly inert the screw caps.
3. Insert the cable conduits. Tighten the cable glands and make sure they are tight.

**INSTALL THE COVER**

- (✍️ 6) Insert the hinges for opening towards the left or right.

Reinstall the cover

OPENING TO THE RIGHT

enclosure cover

---

OPENING TO THE LEFT

cover enclosure

✍️ 6

Fasten the enclosure

1

Ø 5 mm x4

2

x4

3

✍️ 5

**ENGLISH**  
Translation of the original instructions

## 5.2 COMPONENTS

### SWITCHING POWER SUPPLY

The switching power supply is factory set to a nominal mains voltage of 230 V~.

#### SETTING THE MAINS VOLTAGE TO 115 V~

If the mains voltage is 115 V~, the position of the selector has to be changed.



**CARRY OUT THE WORK WITH THE POWER SUPPLY DISCONNECTED.**

1. 7) Disconnect the POWER connector and remove the cover of the board.
2. Remove the E124 board.
3. Remove the cover from the power supply.
4. 8) Place the selector switch to 120 V.
5. Put back the parts and insert the POWER connector.

**Important** there must be spacers in the positions marked C, I, Q, F.

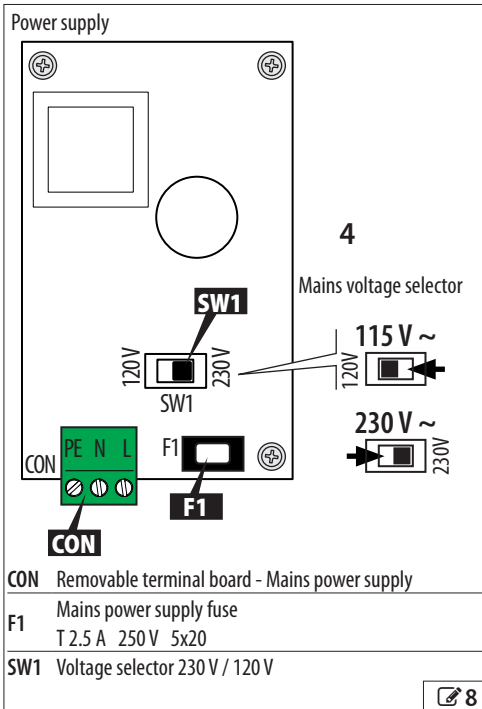

#### Removing the cover from the board

1

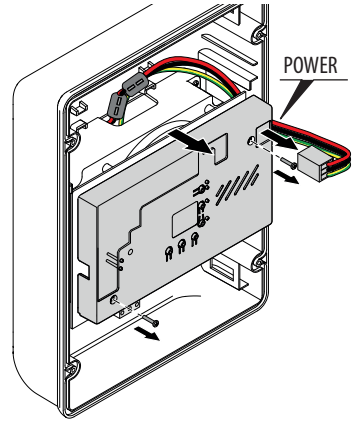

#### Remove the E124 board

2

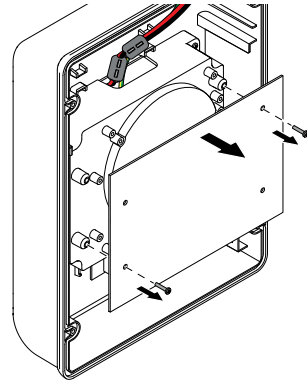

#### Remove the cover from the power supply

3

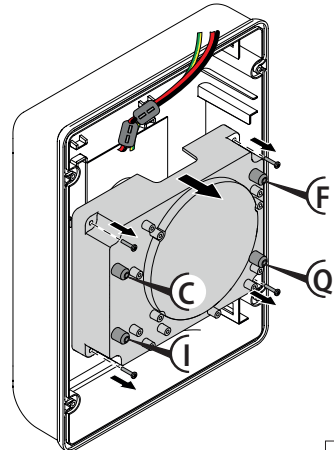



BOARD E124

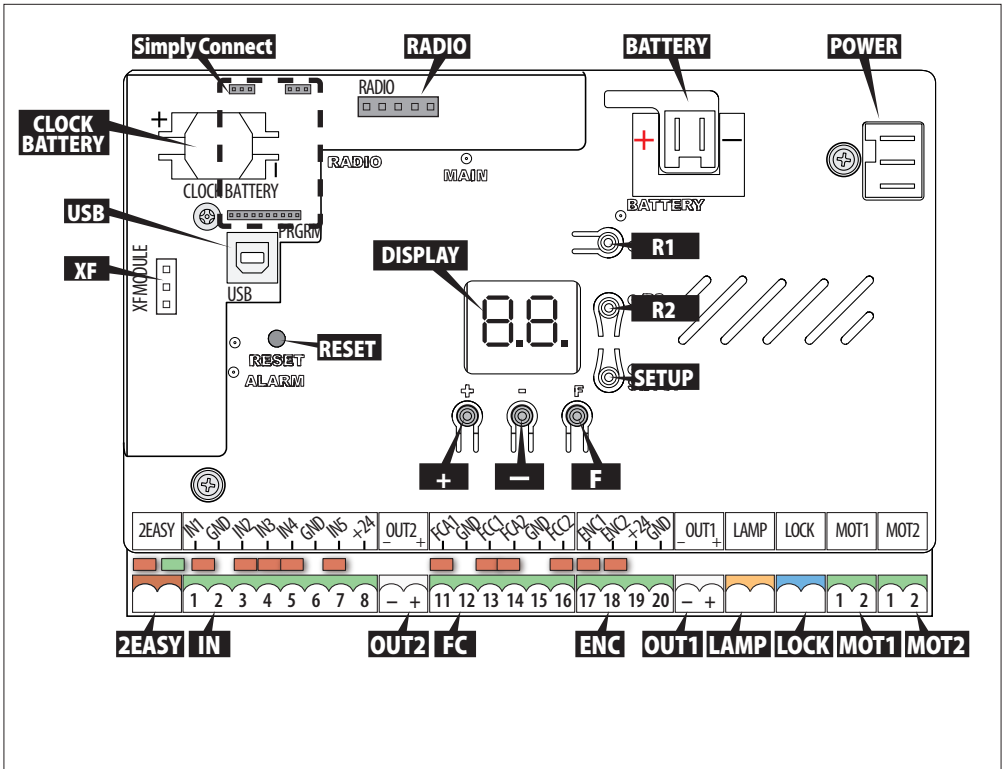

<b>POWER</b>	Connector for switching power supply
<b>BATTERY</b>	Connector for secondary power supply
<b>2EASY</b>	Removable terminal board for BUS 2easy accessories
<b>IN</b>	Removable terminal board for control device inputs (IN1 ... IN5) and accessories power supply
<b>OUT2</b>	Removable terminal board for programmable output
<b>FC</b>	Removable terminal board for limit switch inputs
<b>ENC</b>	Removable terminal board for Gatecoder FAAC inputs on Leaf 1/2
<b>OUT1</b>	Removable terminal board for programmable output
<b>LAMP</b>	Removable terminal board for flashing light output
<b>LOCK</b>	Removable terminal board for FAAC electric lock
<b>MOT1</b>	Removable terminal board for Leaf1 motor
<b>MOT2</b>	Removable terminal board for Leaf2 motor

<b>XF</b>	Connector (3 pin) for XF FAAC radio module
<b>RADIO</b>	Connector (5 pin) for RP/DECODER FAAC/MiniDec boards
<b>USB</b>	USB connector
<b>Simply Connect</b>	Connectors for connectivity module (accessory)
<b>CLOCK BATTERY</b>	Clock battery holder
<b>+ - F</b>	Programming buttons
<b>R1, R2</b>	Radio control memorisation buttons
<b>SETUP</b>	SETUP button
<b>RESET</b>	Recessed RESET button

**i** For a description of the LEDs, see § Diagnostics

ENGLISH  
Translation of the original instructions

## 5.3 CONNECTIONS



**CARRY OUT THE WORK WITH THE POWER SUPPLY DISCONNECTED.** Only turn on the power once installation has been completed (see § Start-up).

### BUS 2EASY (2EASY) DEVICES

Connect the devices to the 2EASY terminal board (chapter § Accessories).



Do not exceed the maximum load of 500 mA.



If no BUS 2easy devices are used, leave the terminals free.

### CONTROL DEVICES (IN)

IN1 GND IN2 IN3 IN4 GND IN5 +24

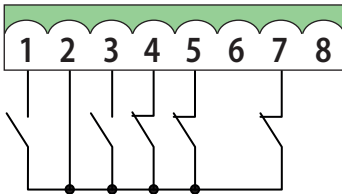

Connect the control devices (buttons or other pulse generators) to the dedicated inputs.



The maximum accessories load is 500 mA. To calculate the maximum power consumption, refer to the instructions of the individual accessories.

#### Control devices terminal board

1	IN1	NO	OPEN A (total motion command)
2	GND		Common contacts
3	IN2	NO	Command determined by the active operating logic: OPEN B (partial motion command) if the automation is using operating logic $\bar{b}$ , $b\bar{c}$ , or $\bar{c}$ , it causes it to CLOSE.
4	IN3	NC	STOP command
5	IN4	NC	Safety in opening command (photocells, sensitive edges..)
6	GND		Common contacts
7	IN5	NC	Safety in closing command (photocells, sensitive edges..)
8	+24		Accessories power supply

**NO type inputs** (normally open) Devices with a NO contact must be connected to NO inputs: the command is activated when the contact closes. Multiple NO contacts on same input must be connected in parallel.

**NC type inputs** (normally closed) Devices with a NC type contact must be connected to NC inputs: the command is activated when the contact opens. If a NC input is not used, it has to be bridged with GND. Multiple NC contacts on same input must be connected in series.



For the installation and operation of the devices, please see the instructions provided.

**Simply Connect** allows the inputs to be programmed in greater detail.

### LIMIT SWITCH (FC)

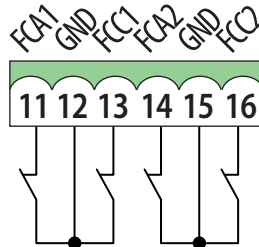

Connect the opening and closing limit switches (if present) to the specific inputs on terminal board FC.

#### Limit switch terminal board

11	FCA1	NC	Opening limit switch Motor1
12	GND		Common contacts
13	FCC1	NC	Closing limit switch Motor1
14	FCA2	NC	Opening limit switch Motor2
15	GND		Common contacts
16	FCC2	NC	Closing limit switch Motor2

If no limit switches are used, there is no need to bridge the contacts. If at least one limit switch is used, any unused contacts must be bridged.

- Functions available in Basic programming:  $\bar{F}A$ ,  $\bar{F}C$  (opening, closing limit switch).

**GATECODER (ENC)**

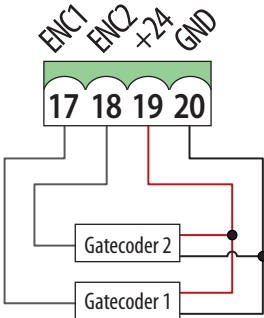

Connect the FAAC Gatecoder encoder (optional) to the ENC terminal board. The figure shows the connection of one Gatecoder on Leaf1 and one on Leaf2. If only one Gatecoder is used, there is no need to bridge unused inputs to ground.

**Gatecoder terminal board**

17	ENC1	Gatecoder on Leaf1
18	ENC2	Gatecoder on Leaf2
19	+24	Accessories power supply
20	GND	Common contacts

- Functions available in Advanced programming:  $\text{E}\square$  (enable/disable the encoders).

**CONFIGURABLE OUTPUTS (OUT1, OUT2)**

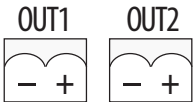

**!** Do not exceed the maximum load for each output: 24 V $\text{==}$  with 100 mA.

Each NO type Open Collector output is activated according to the programmed function.

OUT active	OUT not active
24 V $\text{==}$	open circuit

- Functions available in Advanced programming:
  - $\square 1$  (OUT1 - default: ALWAYS ACTIVE)
  - $\square 2$  (OUT2 - default: LED)
  - $\text{E}1, \text{E}2$  (timing OUT1, OUT2: duration of output, if a timed function is programmed).

**FLASHING LIGHT 24 V $\text{==}$  (LAMP)**

**!** Do not exceed the maximum load 24 V $\text{==}$  with 15 W. The flashing light indicates that the automation is mov-

ing and must be installed in a position that is visible from inside and outside the property.

Connect the flashing light to the intermittent output on the LAMP terminal board.

- Functions available in Advanced programming:  $\text{P}\text{F}$  (pre-flashing - of 3 s before movement,  $\text{R}\text{S}$  scheduled maintenance request - further 8 s of pre-flashing).

**ELECTRIC LOCK (LOCK/ OUT1, OUT2)**

E124 controls an electric lock to block the leaf in the closed position.

Connect the FAAC electric lock to the LOCK terminal board.

If you use an electric lock NOT manufactured by FAAC, connect a suitable 24 $\text{==}$  interface relay to one of the programmable outputs OUT1 / OUT2. Use an external power supply to power the electric lock.

Then program the output for an electric lock NOT manufactured by FAAC (Advanced programming:  $\square 1 / \square 2 = 11$ ).

- Functions available in Advanced programming:  $\text{c}\text{S}$  (closing thrust),  $\text{r}\text{S}$  (reverse stroke in opening),  $\text{E}\text{L}$  (electric lock on Leaf2).

**MOTOR 1 (MOT1)**

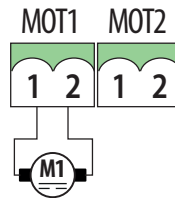

In single leaf automations, the motor must be connected to MOT1.

In 2-leaf automations, the motor of the first leaf that opens (LEAF1) has to be connected to MOT1. This would be the overlapping leaf, if present.

- Functions available in Basic programming:  $\square 1 \square$  (number of motors),  $\text{C}\text{d}$  (closing delay - option for 2-leaf automation).

**MOTOR 2 (MOT2)**

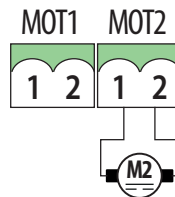

In 2-leaf automations, the motor of the second leaf that

opens (LEAF2) has to be connected to MOT2.

**i** DO NOT connect the motor of a single leaf automation to MOT2.

- Functions available in Advanced programming:  (opening delay - option for 2-leaf automation).

## XF MODULE

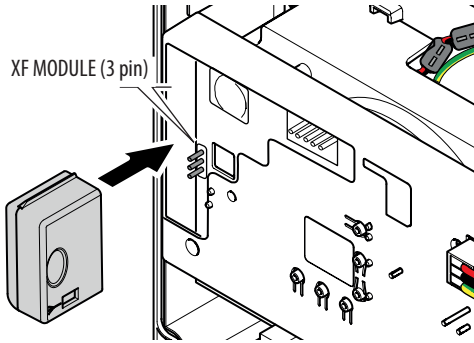

Insert the XF Module into the 3-pin quick insertion connector. Insert it as shown in the figure.

## RADIO RECEIVER/DECODER BOARD

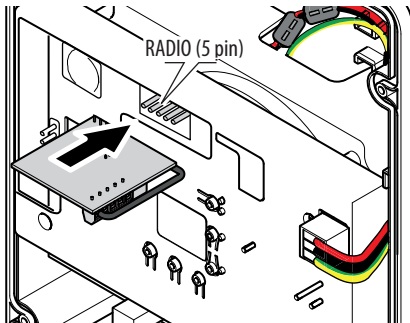

Insert the radio receiver board or the decoder board into the 5-pin quick insertion connector. Insert it as shown in the figure.

**i** If a FAAC RP receiver is used, it is recommended to install the appropriate external antenna in order to obtain a sufficient range (see the device instructions).

## EMERGENCY BATTERIES (BATTERY)

Connect the back-up batteries (dedicated section in the § Accessories chapter) or a stabilized power supply to the BATTERY connector.

**i** Connect before switching on mains power.

## MAINS POWER SUPPLY (CON)

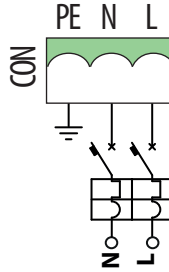

Connect the mains power supply to the CON terminal board on the switching power supply.

Use at least 3G 1.5 mm<sup>2</sup> wires.

**!** It is mandatory to connect to the system earthing conductor.

**i** The switching power supply is factory set to a mains voltage of 230 V~ and is connected to the POWER connector on the board. If the mains voltage is 115 V~, the position of the selector (Switching power supply) has to be changed.

## 6. START-UP

### RISKS



### PERSONAL PROTECTIVE EQUIPMENT



### SET-UP PROCEDURE

Carry out following (§ specific sections).

1. Check the STOP (IN3) and photocell terminals (IN4, IN5): they have to be connected or bridged.

If terminal IN3 is open, it prevents the automation and the SETUP from working.

If terminals IN4 and/or IN5 are open, they prevent the automation but not the SETUP from working.

2. Connect the emergency batteries, if present and then turn power on to the board.
3. Configure the type of automation (Basic programming, cF) and the number of motors (Basic programming, Πn).
4. Enable the encoders, if present (Basic programming, En) and the limit switches (Basic programming, FR, FC).
5. If an electric lock has been installed on leaf2, enable EL=Ψ in advanced programming.
6. Check the leaf movement (Basic programming, Π2, Π1).
7. Carry out the SETUP procedure that includes the registration of BUS 2easy that are connected (Basic programming, EL).
8. Memorise the radio controls, if used.
9. Complete the required programming.
10. Carry out the final checks to make sure that the automation system is working correctly with all the devices installed.
11. Close the board enclosure.

### 6.1 TURN POWER ON TO THE BOARD

Switch on the mains power supply after having connected the emergency batteries, if present.

The MAIN LED lights up and the following appears on the display:

- b0, then the FW version (e.g. 4.0), then S0 (SETUP required). If the SETUP has already been carried out b0, appears on the display and then the automation status (e.g. 00).

For LED and display signals see § Diagnostics.

### 6.2 PROGRAMMING THE BOARD

When the display shows the automation status, you can enter basic or advanced programming mode.

#### ■ BASIC PROGRAMMING

1. Press and hold down the **F** button.
  - The first function (∩∩) appears on the display, which is displayed as long as button F remains pressed.
2. Release the button: the display shows the value of the function.
3. Press the **+** or **-** button to modify, then press the **F** button to confirm to go to the next function.

Proceed in the same way for all the functions (see ∞ Basic programming menu).

#### ■ ADVANCED PROGRAMMING

1. Press and hold down the **F** button, then the **+** button as well:
  - The first function (b0) appears on the display, which is displayed as long as button F remains pressed.
2. Release the buttons: the display shows the value of the function.
3. Press the **+** or **-** button to modify, then press the **F** button to confirm to go to the next function.

Proceed in the same way for all the functions (see ∞ Advanced programming menu).

#### ■ EXITING PROGRAMMING MODE



Every modified value becomes effective immediately, but when exiting from programming mode you have to decide whether to save the modifications or not.

**Modifications are lost** due to TIMEOUT if no buttons have been pressed for 10 minutes or if power to the board is disconnected before they have been saved.

1. Press and hold down the **F** button, then the **+** button as well.
  - Alternatively, scroll through the programming menu until you reach the last function (S0).
2. Select:
  - Ψ = save the changes
  - n0 = DO NOT save the changes
3. Press the button **F** to confirm.
  - the display reverts to the automation status view.

Basic function		DEFAULT:	0	1	2	3	4	5	6	7														
<b>⌘</b>	<b>Simply Connect</b> To enable Simply Connect, select a communication channel (CH 1...4). <input type="checkbox"/> disabled, <b>1</b> (CH 1), <b>2</b> (CH 2), <b>3</b> (CH 3), <b>4</b> (CH 4)						0																	
<b>⌘F</b>	<b>TYPE OF AUTOMATION</b> Select the type of actuator installed (board loads the relative default configuration). <table border="0" style="width: 100%;"> <tr> <td><input type="checkbox"/> no FAAC actuator</td> <td><b>4</b> S418</td> </tr> <tr> <td><b>1</b> 412, 413, 415, 770, 390, 770N</td> <td><b>5</b> S450H</td> </tr> <tr> <td><b>2</b> 391</td> <td><b>6</b> S800H ENC</td> </tr> <tr> <td><b>3</b> S700H/S800H</td> <td><b>7</b> S2500 I</td> </tr> </table>	<input type="checkbox"/> no FAAC actuator	<b>4</b> S418	<b>1</b> 412, 413, 415, 770, 390, 770N	<b>5</b> S450H	<b>2</b> 391	<b>6</b> S800H ENC	<b>3</b> S700H/S800H	<b>7</b> S2500 I						0									
<input type="checkbox"/> no FAAC actuator	<b>4</b> S418																							
<b>1</b> 412, 413, 415, 770, 390, 770N	<b>5</b> S450H																							
<b>2</b> 391	<b>6</b> S800H ENC																							
<b>3</b> S700H/S800H	<b>7</b> S2500 I																							
The DEFAULT settings for the type of automation are indicated in the corresponding column (e.g. column 4 for S418). The letters <b>EP</b> indicate a "mixed" automation: 2 leaves with 2 different actuators (from Simply Connect).																								
<b>⌘F</b>	<b>DEFAULT CONFIGURATION</b> <b>Y</b> indicates if the programming corresponds to the default settings. Select <b>Y</b> if you wish to reload the default values for the type of automation. <b>Y</b> the programming corresponds to the DEFAULT settings <input type="checkbox"/> the programming does not correspond to the DEFAULT settings						Y																	
<b>⌘O</b>	<b>OPERATING LOGICS</b> <table border="0" style="width: 100%;"> <tr> <td><b>E</b> Semi-automatic</td> <td><b>AP</b> Automatic step by step</td> </tr> <tr> <td><b>EP</b> Semi-automatic step by step</td> <td><b>AE</b> Automatic with timer function</td> </tr> <tr> <td><b>S</b> Automatic Safety</td> <td><b>b</b> Semi-automatic b</td> </tr> <tr> <td><b>SA</b> Automatic Safety 2</td> <td><b>b⌘</b> Mixed (Impulse opening / Hold-to-run closing)</td> </tr> <tr> <td><b>SP</b> Automatic step by step</td> <td><b>⌘</b> Hold-to-run</td> </tr> <tr> <td><b>AI</b> Automatic 1</td> <td><b>⌘U</b> Displayed if there is a CUSTOM logic from Simply Connect.</td> </tr> <tr> <td><b>A</b> Automatic</td> <td></td> </tr> </table>	<b>E</b> Semi-automatic	<b>AP</b> Automatic step by step	<b>EP</b> Semi-automatic step by step	<b>AE</b> Automatic with timer function	<b>S</b> Automatic Safety	<b>b</b> Semi-automatic b	<b>SA</b> Automatic Safety 2	<b>b⌘</b> Mixed (Impulse opening / Hold-to-run closing)	<b>SP</b> Automatic step by step	<b>⌘</b> Hold-to-run	<b>AI</b> Automatic 1	<b>⌘U</b> Displayed if there is a CUSTOM logic from Simply Connect.	<b>A</b> Automatic								E		
<b>E</b> Semi-automatic	<b>AP</b> Automatic step by step																							
<b>EP</b> Semi-automatic step by step	<b>AE</b> Automatic with timer function																							
<b>S</b> Automatic Safety	<b>b</b> Semi-automatic b																							
<b>SA</b> Automatic Safety 2	<b>b⌘</b> Mixed (Impulse opening / Hold-to-run closing)																							
<b>SP</b> Automatic step by step	<b>⌘</b> Hold-to-run																							
<b>AI</b> Automatic 1	<b>⌘U</b> Displayed if there is a CUSTOM logic from Simply Connect.																							
<b>A</b> Automatic																								
<b>PA</b>	<b>PAUSE TIME A</b> Displayed only in logics with automatic closing. This function specifies the pause time if the automation has been opened by the OPEN A command. <b>00...59 s</b> Adjustment step: 1 s The display subsequently changes to minutes and tens of seconds (separated by a point) and the time is adjusted in 10 s steps, up to the maximum value of 9.5 minutes. E.g. 1.2 = 1 min and 20 s									30														
<b>Pb</b>	<b>PAUSE TIME B</b> Displayed only in logics with automatic closing. This function specifies the pause time if the automation has been opened by the OPEN B command (adjustment similar to PA)									30														
<b>⌘n</b>	<b>NUMBER of MOTORS</b> enabled. <b>1</b> 1 motor, <b>2</b> 2 motors									2														
<b>F1</b>	<b>MOTOR 1 POWER</b> <b>01...50</b> (levels)		25	25	25	40	25	35	40	15														
<b>F2</b>	<b>MOTOR 2 POWER</b> NOT displayed if $\lceil n = 1$ . <b>01...50</b> (levels)		25	25	25	40	25	35	40	15														
<b>SP</b>	<b>SPEED</b> Speed of movement. <b>01...10</b> (levels)									08														

E <sub>n</sub>	<b>ENCODER</b> Enables/disables the encoder on both motors. no disabled, 4 enabled (* = non modifiable)	no	no	no	4	no	4	4	4
F <sub>A</sub>	<b>OPENING LIMIT SWITCH</b> Enables/disables the opening limit switches, to stop the automation or start the slowdown. Modifying the value requires a new SETUP. no disabled, 01 to stop, 02 to start slowdown					no			
F <sub>C</sub>	<b>CLOSING LIMIT SWITCH</b> Enables/disables the closing limit switches, to stop the automation or start the slowdown. Modifying the value requires a new SETUP. no disabled, 01 to stop, 02 to start slowdown					no			
C <sub>d</sub>	<b>CLOSING DELAY</b> NOT displayed if P <sub>n</sub> = 1. The delay is applied to Leaf 1. 00...59 s Adjustment step: 1 s The display subsequently changes to minutes and tens of seconds (separated by a point), up to a maximum of 1.3 minutes. 1.0...1.3 Adjustment step: 10 s E.g. 1.2 = 1 min and 20 s.					05			
B <sub>u</sub>	<b>BUS 2easyREGISTRATION</b> See the S specific section.					no			
M <sub>2</sub>	<b>MOTOR 2 OPERATION</b> NOT displayed if P <sub>n</sub> = 1. In this function, buttons + and - operate Motor 2 in hold-to-run mode. + OPEN (displaying oP), - CLOSE (displaying cL)					--			
M <sub>1</sub>	<b>MOTOR 1 OPERATION</b> In this function, buttons + and - operate Motor 1 in hold-to-run mode. + OPEN (displaying oP), - CLOSE (displaying cL)					--			
S <sub>E</sub>	<b>SETUP</b> See the S specific section.					--			
S <sub>E</sub>	<b>LEAVING THE PROGRAMMING MODE</b> 4 Exit saving the settings no Exit without saving the programming After having confirmed using button F, the display indicates the STATUS of the automation: 00 CLOSED                    04 in PAUSE                    08 VERIFYING BUS 2easy            12 EMERGENCY CLOSE 01 OPEN                        05 OPENING                    09 PRE-FLASHING and then HP Hold Position 02 STATIONARY THEN        06 CLOSING                    OPENS                                . (point flashing) SLEEP OPENS 03 STATIONARY THEN        07 FAIL- SAFE in progress    10 PRE-FLASHING and then CLOSES                        CLOSES 11 EMERGENCY OPEN					4			

## 3 Advanced programming menu

The DEFAULT settings for the type of automation are indicated in the corresponding column (e.g. column 4 for S418).

Advanced function		DEFAULT:	0	1	2	3	4	5	6	7
b0	<b>MAXIMUM FORCE AT INITIAL THRUST TIME</b> When it starts, the motor operates at maximum power for the time set in this option. 01...10 s Adjustment step: 1 s.		02	02	02	02	02	02	02	03
c5	<b>CLOSING THRUST</b> This function assists the closing of the electric lock: it pushes against the closing stop with maximum force for 2 s. DO NOT enable the function if there is not a mechanical closing stop fitted. Y enabled, n0 disabled (* = not modifiable if FC = 1)						no*			
r5	<b>REVERSE STROKE FOR OPENING</b> NOT displayed if FC = 1. This function assists the release of the electric lock: it pushes against the closing stop for 2 s before opening. DO NOT enable the function if there is not a mechanical closing stop fitted. The reverse stroke is NOT compatible with the closing stop limit switch, for this reason it is not carried out if, after enabling it, you set FC = 1. Y enabled, n0 disabled						no			
EL	<b>ELECTRIC LOCK ON LEAF 2</b> NOT displayed if FN = 1. This function has to be enabled if the electric lock is installed on Leaf 2 (it is usually on Leaf 1). Y enabled, n0 disabled						no			
0d	<b>LEAF OPENING DELAY</b> NOT displayed if FN = 1. This delay is applied to Leaf 2. 00...59 s Adjustment step: 1 s The display subsequently changes to minutes and tens of seconds (separated by a point), up to a maximum of 1.3 minutes. E.g. 1.2 = 1 min and 20 s. 1.0...1.3 Adjustment step: 10 s						02			
ip	<b>REVERSE ON OBSTACLE</b> This function specifies the amount the leaf is reversed after an obstacle has been detected. Y = partial reverse (for 2 s), n0 = complete reverse						no			
r1	<b>LEAF 1 DECELERATION</b> NOT displayed if FA and FC = 2. Specifies the deceleration space for Leaf 1 (% of the total stroke). 00...99 % Adjustment step: 1 %		30	30	30	20	30	20	30	30
r2	<b>LEAF 2 DECELERATION</b> NOT displayed if FN = 1, or if FA and FC = 2. Specifies the deceleration space of Leaf 2 (% of the total stroke). 00...99 % Adjustment step: 1 %		30	30	30	20	30	20	30	30
PF	<b>PRE-FLASHING</b> Enables/disables pre-flashing and specifies when it is activated. The pre-flashing time is fixed: 3 s. n0 disabled 0C for any movement CL when closing OP when opening PA when the pause time elapses						no			
Ph	<b>CLOSING PHOTOCELLS</b> Specifies the operation of the closing photocells. Y reopen when the photocells disengage n0 reopen immediately						no			



Advanced function		DEFAULT:	0	1	2	3	4	5	6	7
Ad	<b>ADMADP FUNCTION</b> Enables/disables operation in accordance with French standard NFP 25/362. Y enabled, no disabled						no			
EC	<b>ANTI-CRUSHING SENSITIVITY</b> This function defines the speed with which the anti-crushing system triggers after an obstacle has been detected. 01 minimum 10 maximum (* = not modifiable)		01 *	06	06	05	06	05	05	06
US	<b>ULTRA-SENSITIVE OBSTACLE DETECTION</b> This function allows a rigid impact to be recognised immediately. Y enabled, no disabled		no	no	no	no	Y	Y	Y	no
rB	<b>SEARCH FOR STOP</b> NOT displayed if FC or FA = 01. This function specifies the angular space in which to search for the opening/closing stop. In this space, the automation is stopped by a mechanical stop/obstacle and not by the anti-crushing system. 0.3... 9.9° Adjustment step: 0.1° Displayed in degrees and tenths of a degree (separated by a point) up to 9.9°, then it is in degrees. 10... 20° Adjustment step: 1°		10	10	10	4.0	10	4.0	4.0	1
SF	<b>SOFT TOUCH</b> NOT displayed if En = Y. This function causes the leaf to reverse slightly after the mechanical stop has been detected. Y enabled, no disabled						no			
o1	<b>OUT1</b> Function of output OUT1. The letters tr indicate TIMER programming (from Simply Connect, not modifiable from the board). 00 disabled 01 FAIL-SAFE 02 LED 03 COURTESY LIGHT (timed) 04 ACTIVE ERROR 05 automation OPEN or PAUSED 06 automation CLOSED 07 automation MOVING 08 automation IN EMERGENCY 09 automation OPENING 10 automation CLOSING 11 electric lock function (timed) 12 SAFETY DEVICE ACTIVE 13 TRAFFIC LIGHT function (active during OPENING and with automation OPEN) 14 timed output that can be activated from the 2 <sup>nd</sup> radio channel OMNIDEC 15 output (step-by-step function) that can be activated from the 2 <sup>nd</sup> radio channel OMNIDEC 16 active during the movement of motor 1 17 active during the movement of motor 2 18 anti-intrusion alarm 19 battery operation						00			
t1	<b>TIMING OUT1</b> Displayed if o1 = 03, 11, 14. Sets the duration of output OUT1, if a timed function is programmed. 1... 59 min Adjustment step: 1 min (if o1 = 03 or 14), 1 s (if o1 = 11)						02			
o2	<b>OUT2</b> Function of output OUT2 (with the same options as o1). The letters tr indicate TIMER programming (from Simply Connect, not modifiable from the board).						02			
t2	<b>TIMING OUT2</b> Displayed if o2 = 03, 11, 14. Sets the duration of output OUT2, if a timed function is programmed. 1... 59 min Adjustment step: 1 min if o2 = 03 or 14, 1 s if o2 = 11						01			

Advanced function		DEFAULT:	0	1	2	3	4	5	6	7
AS	<b>MAINTENANCE REQUEST</b> Enables/disables the maintenance alert when the programmed number of cycles has been reached as specified in the following functions (nc, nd) (specific section in chapter § Maintenance). y enabled, no disabled						no			
nc	<b>THOUSANDS of CYCLES</b> Displays the thousands of cycles that have been performed. 00...65 (programmable if AS=y) To reset the cycle counter: press + and - for 5 s						00			
nd	<b>TENS of CYCLES</b> Displays the tens of cycles that have been performed. 00...53 (if AS=no) 00...99 (programmable if AS=y)						00			
St	<b>LEAVING THE PROGRAMMING MODE</b> y Exit without saving the settings no Exit saving the settings After having confirmed using button F, the display indicates the STATUS of the automation:						y			
	00 CLOSED	04 in PAUSE	08 VERIFYING BUS 2easy	12 CLOSING in EMERGENCY						
	01 OPEN	05 OPENING	09 PRE-FLASHING and then OPENS	HP Hold Position						
	02 STATIONARY THEN OPENS	06 CLOSING	10 PRE-FLASHING and then CLOSES	ing) SLEEP mode (point flash-						
	03 STATIONARY THEN CLOSES	07 FAIL- SAFE in progress	11 OPENING in EMERGENCY							

### 6.3 SETUP

The SET-UP procedure consists of a series of movements during which the board acquires the length of travel and other leaf parameters. The SETUP procedure also registers the BUS 2easy devices that are present.

**The system needs to be SET-UP:** when  $\square$  flashes on the display (e.g. when the automation is first put into operation, after the board has been replaced or after factory settings have been restored). If you wish to modify the length of travel of the leaves. If there are active errors that require the SETUP procedure to be carried out (§ Diagnostics -  $\square$  Errors and Warnings).

#### Checks prior to SETUP

- The automation must not be set to manual mode.
- Input IN3 (STOP), if not used, must be bridged (LED DL3 lit).
- In basic programming: make sure that the settings of the following functions are correct
  - $\square$ F type of automation
  - $\square$ n number of motors
  - $\square$ n encoder (has to be enabled, if present)



While the SETUP procedure is being carried out, prevent transit in the area of movement of the leaves because the safety devices (inputs IN4 and IN5) are disabled.

1. Go to the  $\square$  function in basic programming. The value displayed is --.
  - The leaves must be closed. To close them now, press the + button for Leaf2 and the - button for Leaf1.
2. Press the + and - buttons simultaneously for a few seconds.
  - The display flashes, then the first movement starts and  $\square$  appears on the display.
  - Release the buttons.
3. SETUP starts. The display indicates the current phases with a flashing code (from  $\square$ 1 to  $\square$ 6, see  $\square$  SETUP phases).

**If the SETUP procedure doesn't start or stops before it has been completed, the board exits from programming mode and  $\square$  flashes on the display: check the ERRORS that are present (Chapter § Diagnostics).**

#### $\square$ 4 SETUP phases

Display	Phase	Action required
$\square$ 1	Leaf1 opens slowly: searching for the OPEN position	In phases $\square$ 1 to $\square$ 4, the board automatically recognises the OPEN/ CLOSED positions if there is a MECHANICAL STOP (ground mounted or integrated) or A LIMIT SWITCH ENABLED FOR STOPPING the leaf. Alternatively, THERE MUST BE AN ABSOLUTE ENCODER INSTALLED and the position must be determined using the OPEN A command.
$\square$ 2*	Leaf2 opens slowly: searching for the OPEN position	
$\square$ 3*	Leaf2 closes slowly: searching for the CLOSED position	
$\square$ 4	Leaf1 closes slowly: searching for the CLOSED position	
$\square$ 5	The leaves open at full speed, and slowdown as programmed	no action required
$\square$ 6	The leaves open at full speed, and slowdown as programmed	no action required
$\square$ 0	SETUP has been completed. The board exits from programming mode and the display shows the automation status - closed.	

The phases are carried out automatically in sequence.

\* phase NOT carried out in the case of a single leaf automation.

## 6.4 CONFIGURING MOVEMENTS AND TIMING

### In BASIC PROGRAMMING

- **PA OPEN A pause time, PB OPEN B pause time** In operating logics with automatic closing, the gate remains open for the pause time (configurable specifically for full or partial opening).

- **PN Number of motors** Before carrying out the SETUP procedure, the number of motors has to be configured in order to specify single or two leaf operation.

- **FA Opening limit switch, FC Closing limit switch** If present, the limit switches must be enabled, either for stopping or slowing down the leaf.

- **CD Leaf closing delay** This function is used in 2-leaf automations to prevent interference between leaves and to handle any overlap.

### In ADVANCED PROGRAMMING

- **BO Maximum force at initial thrust time** When it starts, the motor works at maximum force for a few seconds, ignoring the limits set in basic programming (F1, F2). Increase the time in the case of particularly high friction.

- **OD Leaf opening delay** This function is used in 2-leaf automations to prevent interference between leaves and to handle any overlap.

## 6.5 ADJUSTING THE ANTI-CRUSHING SYSTEM

Anti-crushing protection is obtained by limiting the static force exerted by the actuator in the event of impact with an obstacle. When an obstacle is detected, the board also issues a REVERSE command.

The reverse movement (partial or complete, according to function IP) is not active in the search for stop space specified in function rB (automation stopped by obstacle).

**OBSTACLE DETECTION** is carried out by checking the current absorbed by the motor or by using the encoder (if present).

- The fourth consecutive obstacle, which is detected in the same direction and position, is defined as the new mechanical stop of the leaf (when the obstacle is removed, the original length of travel is restored automatically).

The functions used for adjusting the anti-crushing system are listed below. Some allow the static force or the kinetic energy of the leaf on the obstacle to be limited; others configure the reverse on obstacle. Adjust the functions together, taking into consideration the configuration of the automation and the conditions of use. For example, in particularly windy areas, with panelled leaves, if the obstacle detection system is ultra-sensitive or the sensitivity of the anti-crushing system is too high, frequent unwanted reversals can occur.

### In BASIC PROGRAMMING

- **F1 Motor 1 Power, F2 Motor 2 Power** Decrease the value if you want to limit the static force in the event of impact.

- **SP Speed of the movement** Decrease the value if you want to limit the kinetic energy of the leaf on an obstacle.

- **EN ENCODER** If encoders are installed, they must be enabled in order to detect obstacles.

- **US Ultra-sensitive obstacle detection** Recommended for 24 V hydraulic actuators with encoder.

- **rB Search for stop** Reverse on obstacle is not active in the search for stop space. SOFT TOUCH (SF) can be enabled, if necessary.

### In ADVANCED PROGRAMMING

- **IP Reverse on obstacle** Specifies the amount by which the leaf is reversed: complete or for 2 s.

- **r1, r2 Slowdown Leaf1, Leaf2** Specifies the extent of the leaf slowdown near the open / closed positions. Alternatively, the slowdown enabled limit switch can be used (FA, FC in basic programming).

The slowdown allows you to limit the inertial forces and reduce the vibrations of the gate when it is stopping.

- **EC Anti-crushing sensitivity** Specifies the speed at which the anti-crushing system triggers after an obstacle has been detected.

- **SF SOFT TOUCH:** the leaf reverses slightly after the mechanical stop has been detected.

This function allows the impact forces to fall within the limits indicated by current regulations.

**6.6 FINAL CHECKS**

1. Carry out a complete functional test of the automation and all the installed devices.
2. Make sure that the forces generated by the leaf are within the limits permitted by the current regulations. Use an impact force tester in accordance with standard EN 12453. For non-EU countries, if there are no specific local regulations, the static force must be less than 150 N. If necessary, adjust the anti-crushing system and make any other adjustments that may be necessary, also by referring to the actuator instructions.

Refer to the actuator instructions for any additional tests that may be required.

**6.7 CLOSE THE ENCLOSURE**

Close the enclosure using the screws on the cover.

Close the enclosure

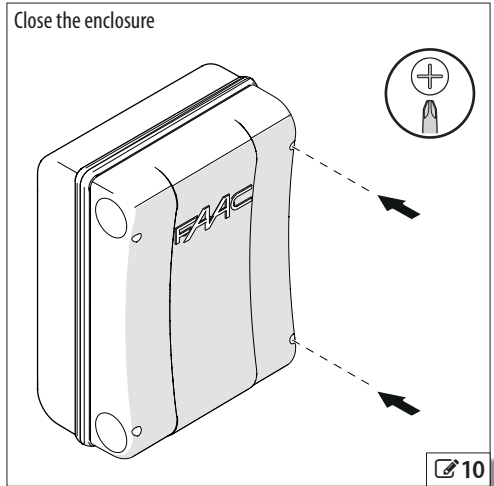

## 7. ACCESSORIES

### 7.1 BUS 2EASY DEVICES

#### BUS 2EASY CONTROL DEVICES



Do not use the BUS 2easy line for emergency stop commands.



BUS 2easy control devices require E124 firmware version FW 3.2 or later.

- Configure the DIP switches on the device to assign 1 or 2 commands.
  - DIP switches for BUS 2easy commands.

**IMPORTANT:** a command (e.g.: OPEN A\_1) can be used with only one of the BUS 2easy control devices connected to the board. Before adding a BUS 2easy control device, check the DIP switches of the devices that are already present.

When multiple devices are connected, assigning the same BUS 2easy command to more than one control device generates an error and prevents the automation from working (**CONFLICT**).

**Example** There are 5 commands available for OPEN A: OPEN A\_1... OPEN A\_5. In order to have OPEN A on two different connected devices, use an OPEN A\_1 and an OPEN A\_2. To add additional devices for OPEN A, use OPEN A\_3 ... and so on.

- Install the devices following the instructions supplied with them.
- Connect to the 2EASY terminal board using two cables without polarity.
- Register the BUS 2easy devices that are connected (see § specific section).
  - note:** BUS 2easy registration is also carried out via the SETUP.

#### 5 BUS 2easy command DIP switches

Key: 0=OFF , 1=ON

DIP switch 5 enables the device for 1 (OFF )command or 2 (ON) commands



0 0 0 0 0	Open A_1	0 0 0 0 1	Open A_1	Open B_1
0 0 0 1 0	Open A_2	0 0 0 1 1	Open A_1	Open B_2
0 0 1 0 0	Open A_3	0 0 1 0 1	Open A_1	Stop
0 0 1 1 0	Open A_4	0 0 1 1 1	Open A_1	Close
0 1 0 0 0	Open A_5	0 1 0 0 1	Open A_2	Open B_1
0 1 0 1 0	Stop	0 1 0 1 1	Open A_2	Open B_2
0 1 1 0 0	Stop NC_1*	0 1 1 0 1	Open A_2	Stop
0 1 1 1 0	Stop NC_2*	0 1 1 1 1	Open A_2	Close
1 0 0 0 0	Close	1 0 0 0 1	Open A_3	Open B_3
1 0 0 1 0	Open B_1	1 0 0 1 1	Open A_3	Open B_4
1 0 1 0 0	Open B_2	1 0 1 0 1	Open A_3	StopNC_1*
1 0 1 1 0	Open B_3	1 0 1 1 1	Open A_3	Close
1 1 0 0 0	Open B_4	1 1 0 0 1	Open A_4	Open B_3
1 1 0 1 0	Open B_5	1 1 0 1 1	Open A_4	Open B_4
1 1 1 0 0	/	1 1 1 0 1	Open A_4	StopNC_2*
1 1 1 1 0	/	1 1 1 1 1	Open A_4	Close

\* Stop NC also generates a stop when the device is disconnected. If you do not require this function, use one Stop.

#### Connecting to the 2EASY terminal board

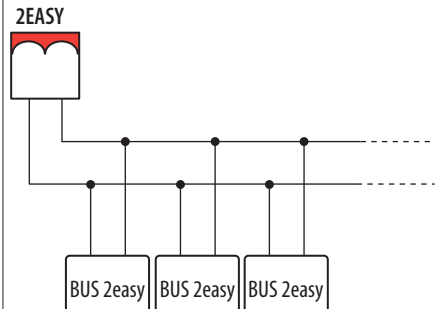

Do not exceed the maximum load of 500 mA.  
The overall length of the BUS 2easy cables must not exceed 100 m.

**BUS 2EASY PHOTOCELLS, SENSITIVE EDGES**



Photocells are additional type D detection devices (according to EN 12453) that reduce the likelihood of contact with the moving leaf. The photocells are not safety devices according to standard EN 12978. Detection devices used as safety accessories (e.g. sensitive edges) to protect against a hazard, must comply with standard EN 12978.

1. Configure the DIP switches on the transmitter and receiver to specify the type of operation and assign an identification code to the pair (ADDRESS).
  - **DIP switches for BUS 2easy photocells and sensitive edges.**

The **CLOSING PHOTOCELLS (CL FSW)** protect the closing area and are active during closing.

The **OPENING PHOTOCELLS (OP FSW)** protect the opening area and are active during opening.

The **OPENING/CLOSING PHOTOCELLS (OP/CL FSW)** protect the entire area of movement and are always active.

The **OPEN PHOTOCELLS** command OPEN A.

**IMPORTANT** in a pair of photocells, both the transmitter and the receiver must have the same DIP switch configuration.

When multiple devices are connected, assigning the same address to more than one detection device generates an error and prevents the automation from working (**CONFLICT**). The addresses of detection devices do not generate conflicts with control devices and vice versa.

2. Install the devices following the instructions supplied with them.
3. Connect to the 2EASY terminal board using two cables without polarity.
4. Register the BUS 2easy devices that are connected (see § specific section).
  - **note:** BUS 2easy registration is also carried out via the SETUP.

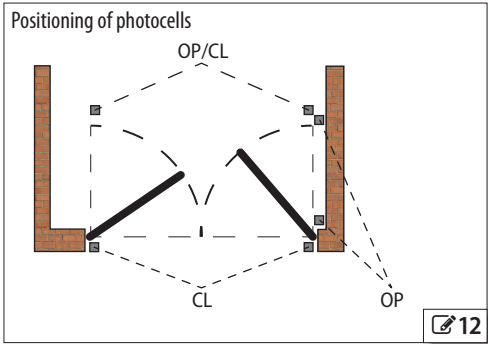

**6** BUS 2easy photocells and sensitive edges DIP switches

Key: 0=OFF , 1=ON

ON	1	2	3	4	
---	---	---	---	---	
1	0	0	0	0	CL FSW
1	0	0	1	1	
1	0	1	0	0	
1	0	1	1	1	
1	1	0	0	0	
1	1	1	0	0	
0	0	0	0	0	OP FSW
0	0	0	1	1	
0	0	1	0	0	
0	0	1	1	1	
0	1	0	0	0	
0	1	0	1	1	OP/CL FSW
1	1	1	1	1	OPEN
1	1	0	1	1	CL Edge
0	1	1	0	0	OP Edge

**Note:** the "Edge" addresses reserved for the sensitive edges must not be assigned to the photocells.

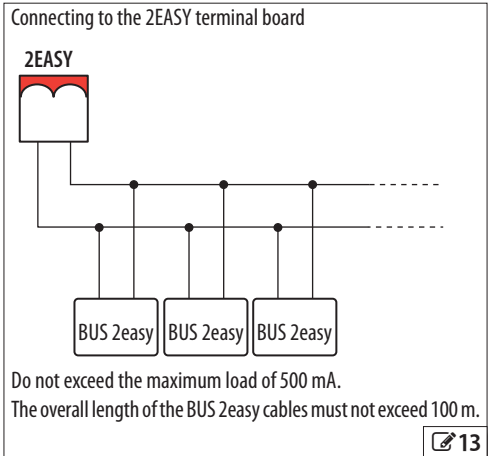

Do not exceed the maximum load of 500 mA.  
The overall length of the BUS 2easy cables must not exceed 100 m.

## BUS 2EASY ENCODER

1. Connect the cables of the encoder to the 2EASY terminal board.
2. After turning on power to the board, check the LEDs on each encoder with the leaf stationary:
  - DL1 lit = encoder powered
  - DL2 lit = encoder connected to **MOTOR1**
  - DL2 off = encoder connected to **MOTOR2**

**i** For each encoder that does not appear to be connected to the correct leaf, temporarily disconnect the power supply and invert the 2 wires on the 2EASY terminal board.

3. Register the BUS 2easy devices using the specific procedure or via SETUP.

## 7.2 REGISTERING/REMOVING BUS 2EASY DEVICES

The SETUP procedure registers the BUS 2easy devices that are connected. Alternatively, you can carry out the following procedure.

1. With the board powered, go to the **bu** function in basic programming. If there are no devices registered, **no** will appear on the display, otherwise a segment will be lit.
  - Press the **+** and **-** simultaneously for at least 5 s.
  - The display flashes, then **u** appears (registration complete).
2. Release the buttons.
  - A lit segment appears on the display. Press the **+** button to check the type of devices registered (**S** Diagnostics).
3. Exiting from programming mode.

To REMOVE BUS 2easy devices that have already been registered, after disconnecting them, repeat the registration (or alternatively the SETUP) procedure.

### SAFEcoder

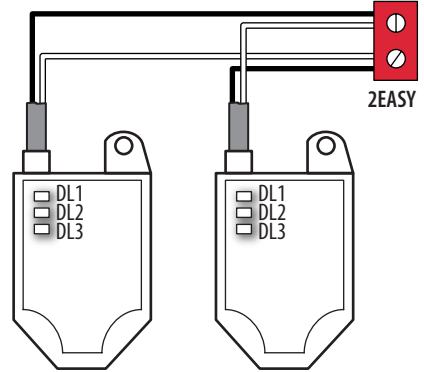

### S800H ENC

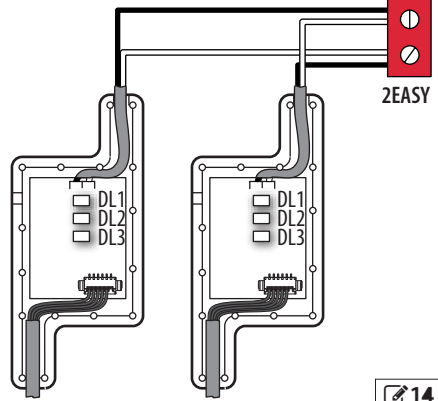

### Correct connections

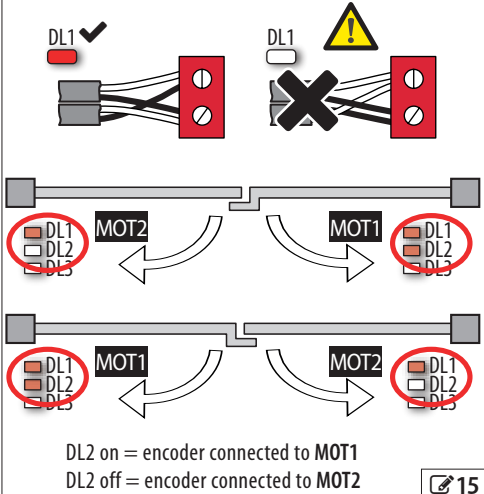



### 7.3 RELAY PHOTOCELLS



Photocells are additional type D detection devices (according to EN 12453) that reduce the likelihood of contact with the moving leaf. The photocells are not safety devices according to standard EN 12978. Detection devices used as safety accessories (e.g. sensitive edges) to protect against a hazard, must comply with standard EN 12978.

Using relay photocells with NC contact. If multiple photocells are used, the contacts must be connected in series. If inputs IN4 and IN5 on the board are not used, they must be bridged to the GND terminal (or to the output programmed as FAIL-SAFE, if enabled).

Position and connect the photocells according to their required use:

**CL - CLOSING PHOTOCELLS** Active during closure in their detection area.

**OP - OPENING PHOTOCELLS** Active during opening in their detection area.

**OP/CL - OPENING AND CLOSING PHOTOCELLS** Always active in their detection area.

### FUNCTIONAL TEST (FAIL-SAFE)

If enabled, the functional test is carried out before each movement and the board momentarily interrupts the power supply to the transmitters and checks the change in status of the input. If the test fails, the board generates an error and prevents the automation from moving.

1. Connect the negative of the transmitter to the negative of output OUT1 or OUT2.
2. Enable the FAIL-SAFE test on the output used:
  - in Advanced programming,  $\square 1$  or  $\square 2 = \square 1$

Positioning the photocells

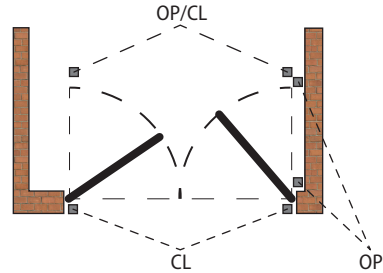

Connecting 1 pair of closing or opening photocells

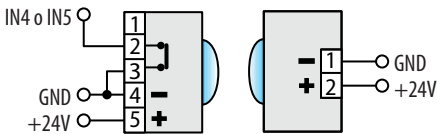

Connecting 1 pair of opening and closing photocells

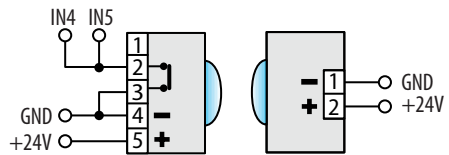

Connecting 2 pairs of closing or opening photocells

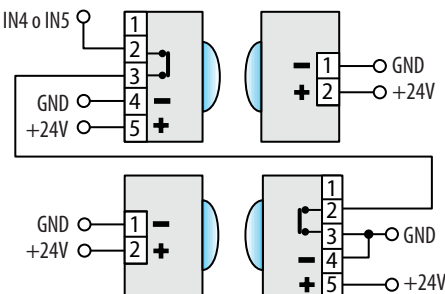

Connecting 1 pair of closing photocells and 1 pair of opening and closing photocells

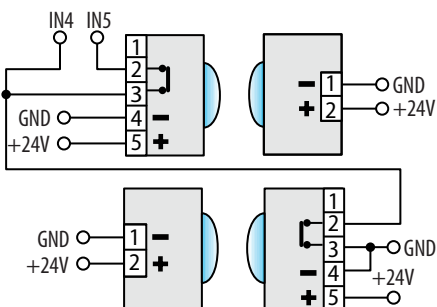

## 7.4 RADIO CONTROLS - SLH/SLHLR

Memorise the first MASTER radio control on the board, then add other radio controls that are required.

### MEMORISING THE MASTER ON THE BOARD

A "MASTER" radio control has to be used. OPEN A and OPEN B commands have to be memorised separately.

**To check if it is a MASTER radio control** Press and hold down a button and watch the LED:

- flashes briefly, then the light becomes steady = MASTER
- turns on immediately with a steady light = NON MASTER

**i** Whenever a master is memorised on the board, any SLH/SLHLR radio controls that are already in use are disabled.

This memorisation procedure for the MASTER applies to the integrated OmniDEC receiver combined with the 3-pin plug in module (it allows OPEN A and OPEN B commands to be memorised).

If a 5-pin plug in receiver is used (only for OPEN A command), follow the specific instructions.

### MEMORISING OPEN A

1. Press the + (or R1) button on the board and release it when LED R1 starts to flash, for 20 s (time available for the next steps).
2. Press buttons P1 and P2 simultaneously on the radio control and release them when LED starts to flash, for 8 s (time available for the next step).
3. On the radio control, held at approximately 50 cm from the board, press button P1 and check LED R1 on the board: it becomes steady for 1 s and then switches off (memorisation complete).
4. Release the button.

When using the memorised button for the first time, press it twice in succession to obtain the command.

### MEMORISING OPEN B

Proceed as for memorising OPEN A, using the - (or R2) button combined with LED R2 and button P2 on the board.

### ADDING RADIO CONTROLS

It is necessary a MASTER that is already in use. It is not necessary to be close to the board.

#### OPEN A COMMAND

1. Press buttons P1 and P2 simultaneously on the MASTER board that is already in use and release them when LED starts to flash, for 8 s (time available for the next step).
2. Press and hold down button P1 and check the LED: it becomes steady.
3. Without releasing the button, position the front of radio control to be added so that it is in contact with

that of the master. Press and hold button P1 on the radio control to be memorised and check the LED: it flashes twice and then switches off.

4. Release both.

When using the memorised button for the first time, press it twice in succession to obtain the command.

#### OPEN B COMMAND

Proceed as for copying OPEN A, using button P2 at steps 2 and 3.

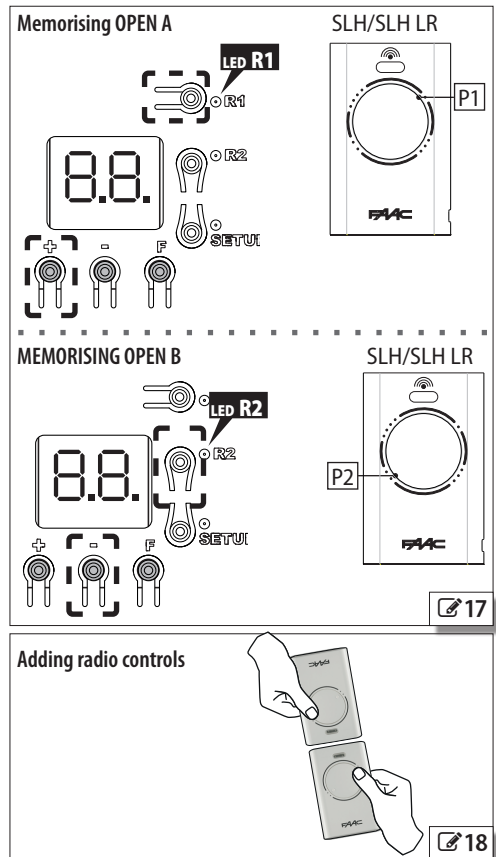

## 7.5 RADIO CONTROLS - RC/LC

### MEMORISING THE RADIO CONTROLS ON THE BOARD

This memorisation procedure applies to the integrated OmniDEC receiver combined with the 3-pin plug in module (it allows OPEN A and OPEN B commands to be memorised).

If a 5-pin plug in receiver is used (only for OPEN A command), follow the specific instructions.

#### MEMORISING OPEN A

1. Press the **+** (or R1) button on the board and release it when **LED R1** starts to flash, for 20 s (time available for the next step).
2. Press and release button **P1** on the radio control. The command is executed immediately and **LED R1** on the board becomes steady for 2 s (memorisation completed), then starts to flash again. Another radio control can be memorised within 20 s.

The procedure ends after 20 s when **LED R1** switches off. To add additional radio controls, repeat the procedure from step 1.

#### MEMORISING OPEN B

Proceed as for memorising OPEN A, using the **-** (or R2) button combined with **LED R2** and button **P2** on the board.

### ADDING RADIO CONTROLS

Use a LC/RC radio control that is already use by the automation, without having to use the board.

#### OPEN A COMMAND

1. Take a radio control that is already in use, on one of the two (OPEN A or OPEN B) channels and move close to the board.
2. Press buttons **P1** and **P2** simultaneously on the radio control that is already in use and release them when the LED starts to flash slowly for 5 s (time available for the next step).
3. Press and hold down button **P1** and check the LED on the board: starts to flash, for 20 s (time available for the next step).
4. Press button **P1** on the new radio control. Check **LED R1** on the board: it becomes steady for 2 s (memorisation complete), then starts to flash again and it is possible to memorise OPEN A on the new radio control within 20 s.

The procedure ends after 20 s when the LED on the board switches off. To add additional radio controls, repeat the procedure from step 1.

#### OPEN B COMMAND

Proceed as for OPEN A, using button **P2** on the radio control at steps 2 and 3 and checking **LED R2** on the board.

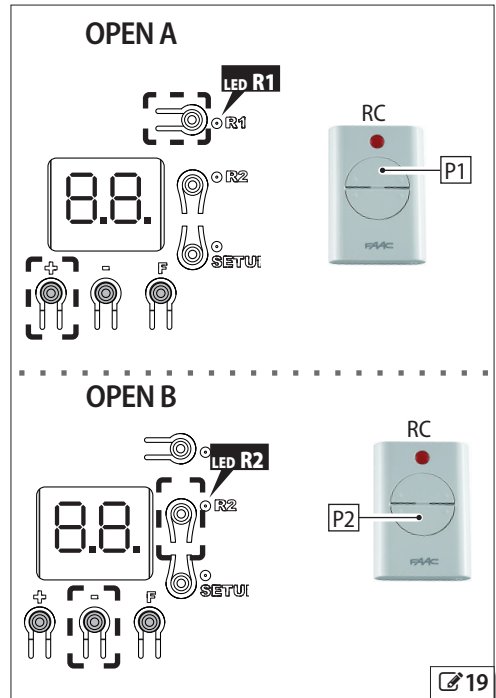

## 7.6 RADIO CONTROLS - DS

### MEMORISING RADIO CONTROLS ON THE BOARD

This memorisation procedure applies to the integrated OmniDEC receiver combined with the 3-pin plug in module (it allows OPEN A and OPEN B commands to be memorised).

If a 5-pin plug in receiver is used (only for OPEN A command), follow the specific instructions.

Configure the 12 DIP switches on the radio control (see the instructions supplied).

The memorisation procedure makes all the radio controls with the same DIP switch configuration operational.

#### MEMORISING OPEN A

1. Press the **+** (or R1) button on the board and release it when **LED R1** starts to flash, for 20 s (time available for the next step).
2. On the radio control, held at approximately 50 cm from the board, press and release button **P1**. The command is executed immediately and LED R1 on the board becomes steady for 1 s, then switches off (memorisation complete).

#### MEMORISING OPEN B

Proceed as for memorising OPEN A, using the **-** (or R2) button combined with **LED R2** and button **P2** on the board.

## 7.7 DELETING ALL RADIO CONTROLS



This operation cannot be undone and will delete all the radio controls of any type (SLH/SLHLR, LC/RC, DS).

Deletion can take place when the status of the board appears on the display.

1. Press the **-** (or R2) button and do not release it until the LED sequence has finished:
  - after 5 s **LED R2** starts flashing slowly
  - after 5 s **LED (R2 and R1)** both start to flash quickly (deletion in progress)
  - after 5 s both the **LEDs** come on steadily (deletion complete)
2. Release the button, both LEDs switch off after approximately 10 s.

### OPEN A

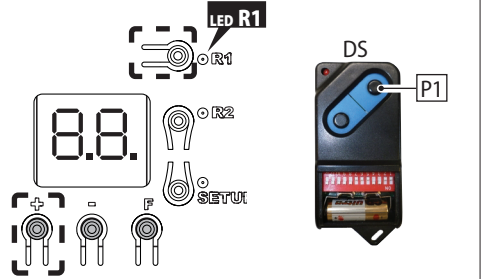

### OPEN B

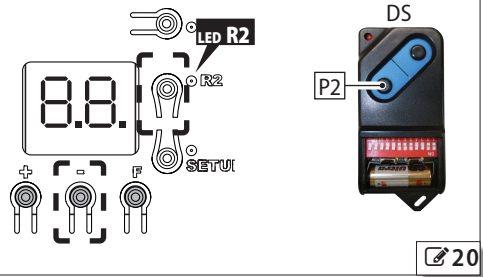

## 7.8 SIMPLY CONNECT



To safeguard people and property, the automation must be supervised and there must not be any unauthorised persons present for the entire duration of operations carried out remotely (SETUP and/or modifications to operating parameters).



Simply Connect requires E124 firmware version FW 4.0 or later.

When programming is taking place via Simply Connect, programming via the board is inhibited.

1. Insert the module into the dedicated plug connectors.
2. With the board powered, check the signalling LEDs (see module instructions).
3. Enable communication by assigning a channel (CH) to the board.

Basic programming, function  $\square C$  :

- 1 CH1, 2 CH2, 3 CH3, 4 CH4

**IMPORTANT** if the automation is in a Multicom network, assign a different channel compared to the other boards that are connected.

4. Install the Simply Connect installer App (supplied with the module).

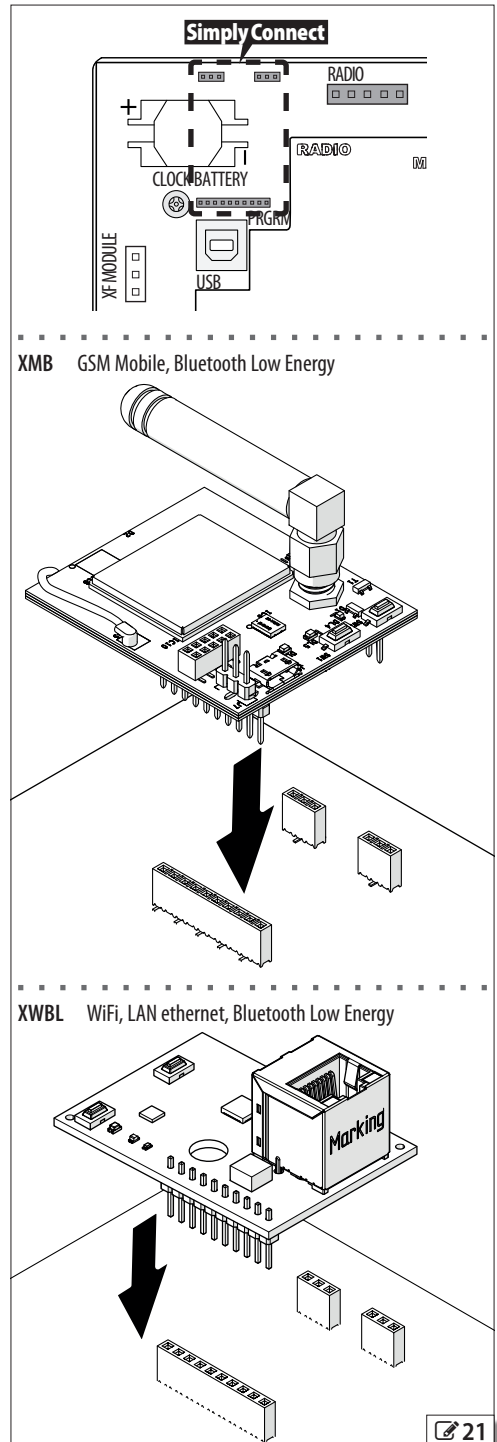

## 7.9 EMERGENCY BATTERIES

Use rechargeable lead batteries that can supply: Voltage 20...28 V  $\approx$ , Current 16 A max.

To install, use the BATTERY SUPPORT KIT (see FAAC catalogue - includes the connection cables).

1. Remove the cover and set up the enclosure:



To prevent the risk of explosion due to the build up of gas generated by lead batteries, drill a  $\varnothing$  1 mm hole in the enclosure. The hole must be at the top of the battery compartment and must not allow water to get into the enclosure.

2. Insert the support and rest the batteries on it.
3. Connect the cables supplied to the battery terminals, following the polarity shown.
4. Make sure that the main power connector (POWER) is already plugged in, then connect the batteries to the BATTERY connector.
  - The battery operation signal can be enabled, in programming, on a programmable output (OUT1, OUT2).
  - Check the BATTERY LED (§ Diagnostics).
5. Replace the cover of the enclosure.

**Simply Connect** also allows you to program:

- which movement is carried out before going into SLEEP mode (last movement OPEN OR CLOSE)
- when the last movement is carried out (IMMEDIATELY or when the threshold value is reached).

## 7.10 EXTERNAL POWER SUPPLY

As an alternative to the 230 V mains power supply, an external stabilized power supply, which can supply the following power, can be connected to the BATTERY connector:

Voltage 20...28 V  $\approx$  , Current 16 A max



Use programming via Simply Connect to disable the battery charging function (only with Simply Connect)

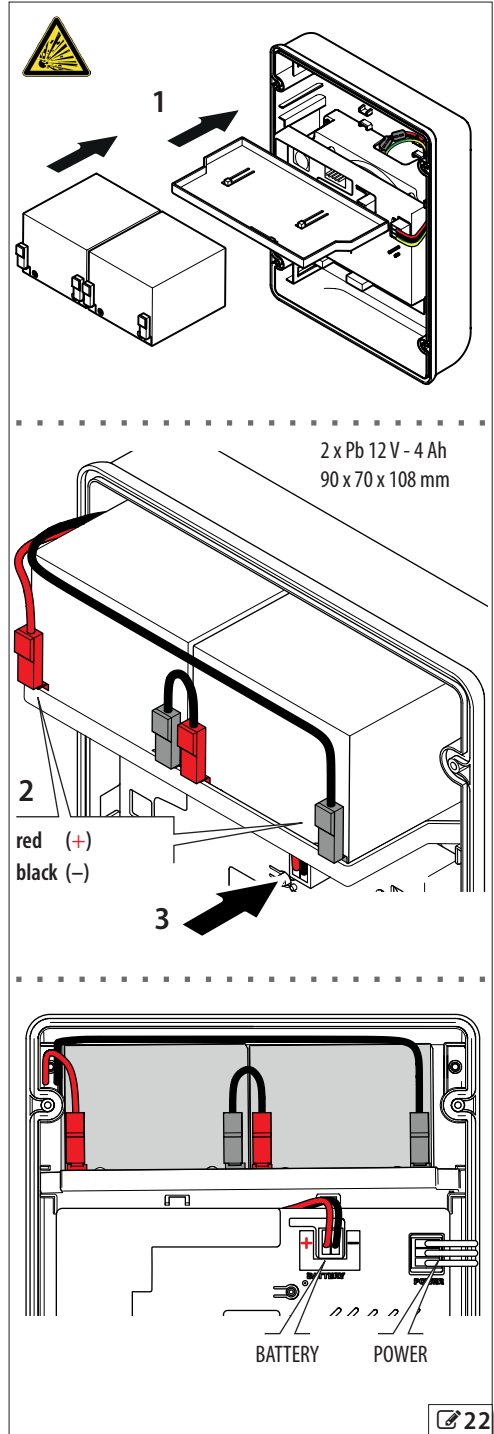

## 8. DIAGNOSTICS

### SIGNALLING LEDs ON THE BOARD

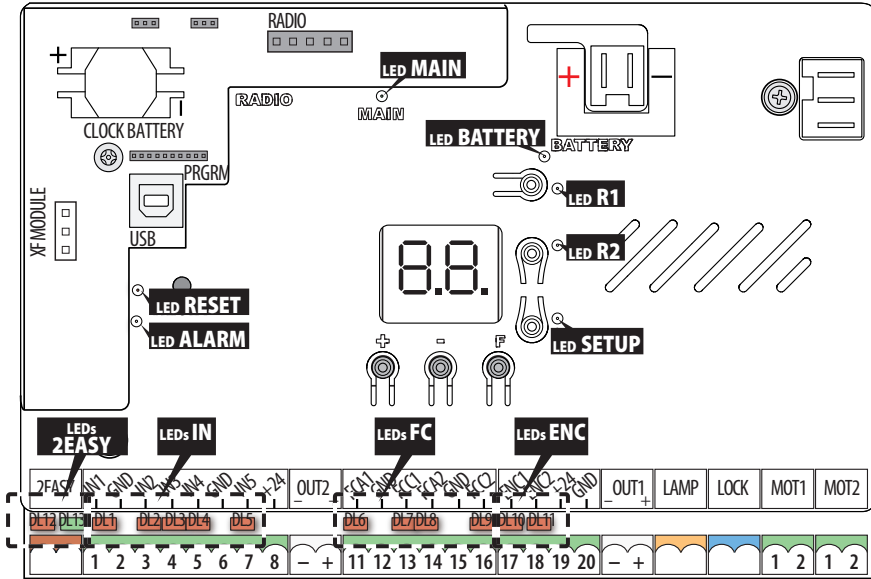

IN1 (DL1)	OPEN A command	● active ○ not active	2EASY BUS 2easy operation	● At least one device in operation ○ NO devices in operation
IN2 (DL2)	OPEN B command	● active ○ not active ←	RED (DL12)	(detectors or pulse generators in operation)
IN3 (DL3)	STOP command	● not active ← ○ active	2EASY BUS 2easy diagnostics	● OK (normal operation) ○ SLEEPING
IN4 (DL4)	Opening protection command	● photocells not engaged ← ○ photocells engaged	GREEN (DL 13)	* SHORT CIRCUIT * ERROR
IN5 (DL5)	Closing protection command	● photocells not engaged ← ○ photocells engaged	MAIN (DL14)	Mains power supply
FCA1 (DL6)	Opening limit switch	● not engaged ← ○ engaged	BATTERY	Secondary power supply
FCC1 (DL7)	Closing limit switch	● not engaged ← ○ engaged	R1	● battery charged ○ battery discharged * battery operation, or battery is charging
FCA2 (DL8)	Opening limit switch	● not engaged ← ○ engaged	R2	Radio Channel 2
FCC2 (DL9)	Closing limit switch	● not engaged ← ○ engaged	SETUP (DL18)	SETUP phases
ENC1 (DL10)	Gatecoder Leaf1	* moving	RESET	RESET
ENC2 (DL11)	Gatecoder Leaf2	* moving	ALARM	Errors, Warnings
				● in progress ○ not running ● in progress ○ not running ● error in progress * warning in progress ○ no warnings

← condition with the board powered, the gate at the halfway position and no connected devices active.

## FIRMWARE VERSION (FW)

The FW version of the board (e.g. 4.0) is shown on the display for 1 s each time it is switched on, after which the automation status is shown.

## STATUS OF THE AUTOMATION

The automation status is shown by a code on the display, when the board is not in the programming menus (Automated system status).

## CHECKING THE MOVEMENT

Access basic programming and use function 12 for Leaf2 (displayed if the automation is configured for 2 leaves) and function 11 for Leaf1.

1. The function displays --.
2. Use buttons + and - in dead man mode. One of the expected commands must be given:

- + to OPEN (OP on the display)
- to CLOSE (CL on the display)

Otherwise, temporarily disconnect the power supply and invert the polarity of the motor connection.

**IMPORTANT** If the automation has 2 leaves, end the test with the leaves positioned so there is no interference between them.

## BUS 2EASY STATUS

To check the BUS 2easy connection, look at the 2EASY LEDs on the board.

RED	●	At least one device is in operation
(DL12)	○	NO devices in operation
GREEN	●	OK
(DL 13)	○	SLEEPING
	*	SHORT CIRCUIT
	*	ERROR

The status of the BUS 2easy is also shown in the BU function in Basic Programming (24).

## WARNINGS FROM A PROGRAMMABLE OUTPUT

The available warnings can be enabled via programmable outputs (OUT1, OUT2) (see advanced programming, functions 01, 02).

## 7 Automated system status

00 Closed	07 Failsafe in progress
01 Open	08 BUS 2easy device verification in progress
02 Stationary then opens	09 Pre-flashing and then opens
03 Stationary then closes	10 Pre-flashing and then closes
04 In pause mode	11 Opening in Emergency
05 Opening	12 Emergency close
06 Closing	13 Hold Position

### BUS 2easy status

Basic Programming, function BU displays the status:

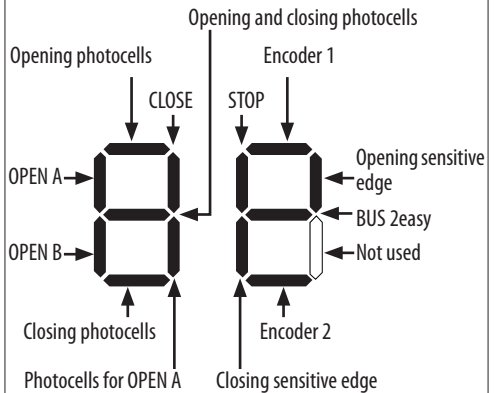
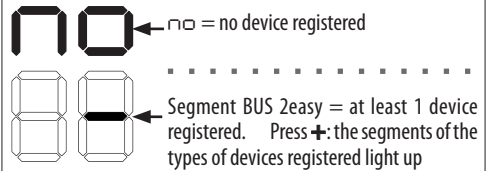

E.g.: 1 or more OPEN A control devices and closing photocells are registered:

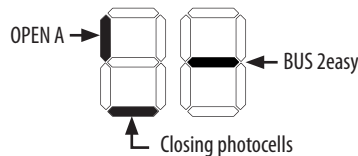



**ERROR CODES, ALARMS/INFO**

When the ALARM LED is lit, notifications in progress can be seen on the display (e.g. E1 07, or multiple notifications e.g. E1 07 16):

- when the board is not in the programming menus, press **+** and **-** at the same time.

**8 Errors, Alarms, Info**

**Error** (number on white background) - **Alarm** (number on grey background) - **Info** (i).

00	No notification	
01	Board failure	Perform RESET. If the problem persists, replace the E124.
02	Board thermal protection	Thermal overload protection active. Wait for the E124 to cool down. Check for overloads.
06	Encoder 2 fault	Make sure that the encoder is connected properly. If the problem persists, replace the encoder.
07	Motor 1 fault	Motor disconnected or short-circuited.
08	Motor 2 fault	Check the wiring. If the problem persists, replace the motor.
16	Encoder 1 fault	Make sure that the encoder is connected properly. If the problem persists, replace the encoder.
20	FAIL-SAFE test failed	FAIL-SAFE test of a device failed. Check the connections, programming, and that the safety devices are working correctly.
22	Programming data corrupted	Programming data NOT valid or corrupted. Repeat BUS 2easy programming and the registration.
24	Consecutive obstacles in closing	The programmed number of consecutive obstacles in closing has been reached. Remove the obstacle. If the problem persists, repeat the SETUP.
25	LOCK1 fault	Check the LOCK1 connection. Remove the cause of the short circuit.
30	Flashing light short circuit / overload	Check the flashing light connection.
31	Consecutive obstacles in opening	The programmed number of consecutive obstacles in opening has been reached. Remove the obstacle. If the problem persists, repeat the SETUP.

32	Motion timeout	The movement is in timeout. Check the manual release of the motors. Check the presence of mechanical stops. If limit switches are installed, make sure that they activate correctly. If the problem persists, replace the board or motor.
35	BUS 2easy device fault / conflict	Check the addresses of the devices.
36	BUS 2easy short circuit / overload	Check the connections of the BUS 2easy devices that are connected and registered.
38	Programming parameters changed	Modified programming, NOT consistent with the SETUP. E.g. 2-leaf operation has been enabled after having carried out the SETUP for a single leaf, (reprogram 10 = 1 or repeat the SETUP). Restore the previous settings or carry out the SETUP procedure.
39	SETUP incorrect or missing	Perform SETUP.
41	(i) Date/time missing	TIMER date/time missing. Replace the buffer battery BAT1 - CR2032, then reset the time and date on the board (from <b>Simply Connect</b> ).
42	(i) Partial open	Automation is in partial open mode.
44	(i) Emergency input active	Check the emergency input (programmable via <b>Simply Connect</b> ).
48	Limit switch fault, leaf 1	Leaf limit switch fault. Check the connection of the limit switches.
49	Limit switch fault, leaf 2	Leaf limit switch fault. Check the connection of the limit switches.
56	(i) Battery operation	The notification remains as long as the automation is operating on the battery due to a mains power failure.
60	Maintenance request	Ask the installer to carry out scheduled maintenance.
61	Obstacle detected Leaf1	An obstacle that prevents the leaf from moving has been detected. Remove the obstacle.
62	Obstacle detected Leaf2	as above
63	Intrusion attempt in progress	An attempt to open the leaf manually has been detected. Start a movement.
65	SETUP in progress	SETUP is in progress. The notification remains as long as the phase is in progress
67	(i) Low energy consumption mode	E124 is operating on battery, in SLEEP mode.

70	Battery discharged	The charge level of the emergency battery is too low for the movements to be carried out.
76	Radio code memory full	The radio memory is full. <b>Simply Connect</b> allows you to delete any unused radio codes. Use an additional MiniDec/DECODER/RP module if necessary.
80	Safeties in opening disabled	The opening safety devices have been disabled (via <b>Simply Connect</b> ).
81	Safeties in closing disabled	The closing safety devices have been disabled (via <b>Simply Connect</b> ).
82	Opening sensitive edge disabled	The opening sensitive edges have been disabled (via <b>Simply Connect</b> ).
83	Closing sensitive edges disabled	The closing sensitive edges have been disabled (via <b>Simply Connect</b> ).
86	(i) BUS 2easy disconnected	BUS 2easy disconnected (via <b>Simply Connect</b> ).
87	BUS 2easy device registration in progress	A registration procedure is in progress.
90	Programming in progress	Programming in progress, e.g. maintenance (via <b>Simply Connect</b> ).
99	Control board data deletion	All data on the E124 has been deleted.
100	Control board communication error	The E124 and the <b>Simply Connect</b> devices do NOT communicate.
101	(i) <b>Simply Connect</b> device FW update in progress	An "Over The Air" FW update of the <b>Simply Connect</b> device is in progress.
102	(i) Control/Component board FW update file download in progress	The FW update for the E124 or one of its components is being downloaded.
103	Control/Component board FW update in progress	The FW of the E124 or one of its components is being updated.
104	Control board awaiting FW update	E124 is waiting for FW update.
107	(i) Acquiring radio on channel 1 in progress	Radio channel 1 is being memorized.
108	(i) Acquiring radio on channel 2 in progress	Radio channel 2 is being memorized.
110	(i) Board Display locked	The display of the E124 is locked (via <b>Simply Connect</b> ).

111 Control/Accessory The FW of the E124 or one of its accessories is being updated via progress: it is not **Simply Connect**. E124 is not operational.  
commands or change parameters

## RESET

Press the RESET button lightly with a thin screwdriver.

- The RESET LED lights up and the board is restarted.

## 9. MAINTENANCE

### RISKS





### PERSONAL PROTECTIVE EQUIPMENT



### 9.1 ROUTINE MAINTENANCE

The table lists the operations that should be performed on a regular basis on the E124 board in order to keep the automation working reliably and safely; these are given purely as a guideline and should not be considered exhaustive. The installer/machine manufacturer is responsible for drawing up the maintenance plan for the automation, supplementing this list or modifying the maintenance intervals according to the machine characteristics.

 Always shut off the power supply before performing any maintenance operations. If the power disconnect switch is not in view, place a "WARNING - Maintenance in Progress" sign on it. Restore the power supply only after finishing any maintenance work and restoring the area to normal.

 Maintenance must be performed by the installer or a maintenance technician.  
Follow all safety recommendations and instructions given in this manual.  
Mark off the work site and prohibit access/transit. Do not leave the work site unattended.  
The work area must be kept tidy and clear upon completing maintenance.  
Before starting work, wait for any hot components to cool down.  
Do not make any modifications to the original components.  
FAAC S.p.A. shall bear no liability for damage or injury due to components that have been modified or otherwise tampered with.

 The warranty shall be forfeited in the event of tampering with components.  
Only use original FAAC spare parts.

### 9 Scheduled maintenance

Operations	Frequency (months)
<b>Electronic equipment</b> Check the condition of the electronic board enclosure, the power cables, the connection cables, the cable glands and the junction boxes and the plastic board protection covers. Check that the connectors and wiring are intact. Check that there are no signs of overheating, burning etc. of electronic components. Check that the earth connections are intact and that the circuit breaker and differential switch are working correctly.	12
Check that the encoders operate correctly when an obstacle is detected.	6
<b>Control devices</b> Check that the installed control devices and radio controls are in good condition and that they operate correctly.	12
<b>Emergency batteries</b> Check that the automation works correctly when operating on battery.	12
<b>Sensitive edges</b> Check that the sensitive edges operate correctly when an obstacle is detected.	6
<b>Photocells</b> Check that each pair of photocells is working correctly. Check that there is no optical/light interference between the pairs of photocells.	6
<b>Indicator light devices</b> Check that they are properly fastened, intact and operating correctly.	12
<b>Electric locks</b> Check that they are properly fastened, intact and operating correctly. Clean the seats.	12
<b>Access control</b> Check that the gate opens only when an authorised user is recognised.	12
<b>Complete automation system</b> Check that the automation system operates correctly, according to the set parameters, when using the various control devices. Check that the gate moves correctly - smooth, regular and without abnormal noise. Check that both the opening and closing speed are correct and that the stop positions and slow-downs provided for are respected. Check that the limit switch is intact and that it operates correctly. Check that all the connected devices are operating correctly in addition to those in the list.	6
Check that the maximum force required to move the leaf manually is less than 225 N in residential areas and 260 N in industrial or commercial areas. Check the force limitation curve (standard EN 12453). For non-EU countries, if there are no specific local regulations, the force must be less than 150 N.	

## CYCLE COUNTER

### READING THE CYCLES PERFORMED COUNTER

Add together the readings of functions  $\overline{00}$  (thousands) and  $\overline{01}$  (tens) in ADVANCED programming.

### RESETTING THE CYCLE COUNTER

In ADVANCED programming, with the function  $\overline{05}$  =  $\overline{00}$ , go to function  $\overline{00}$  and press **+** and **-** for 5 s.

### MAINTENANCE REQUESTED

It is possible to program the number of cycles after which maintenance is required.

When the automation reaches the set number of cycles, there is a pre-flashing of at least 8 s at each cycles, there is a pre-flashing of at least 8 s at each movement. The user should ask the installer to carry out maintenance.

1. In ADVANCED programming, function  $\overline{05}$ , select  $\overline{01}$  to enable the maintenance request.
2. In function  $\overline{00}$  set the value in thousands using the **+** and **-** buttons.
3. In function  $\overline{01}$  set the value in tens using the **+** and **-** buttons.
4. Exit and save the programming.

## 9.2 RESTORING FACTORY SETTINGS

The procedure:

- restores all the default settings of the board
  - deletes the SETUP
  - deletes all the radio controls
  - resets the cycle counter
1. With the board not powered, switch on mains power (the MAIN LED lights up).
  2. A few seconds after having been switched on, while the display shows the FW version (e.g.  $\overline{4.0}$ ), press and hold down the buttons **+**, **-**, **F** simultaneously.
    - After approximately 10 s, **--** appears on the display and LEDS R1 and R2 light up.
  3. Release the buttons.
    - LEDs R1 and R2 switch off.
    - After approximately 10 s,  $\overline{50}$  flashes on the display (SETUP required).

## 10. OPERATION

### COMMANDS

#### ■ OPEN A - TOTAL MOTION

Total motion is 100% of the length of travel. In 2-leaf automations, Leaf1 starts opening first (if the delay is programmed).

#### ■ OPEN B - PARTIAL MOTION

In single leaf automations, partial motion is 50% of the length of travel.

In 2-leaf automations, partial motion is 100% of the length of travel of Leaf1. Leaf1 starts opening first (if the delay is programmed).

#### ■ STOP - STOPS UNTIL THE BUTTON IS RESET.

### BATTERY OPERATION (IF PRESENT)

When there is no mains power, the automation operates on battery until the charge level drops to the threshold value: 16 V<sub>min</sub>.

**WARNING** The frequency at which the flashing light flashes increases with every movement carried out in battery operation mode. A warning can be also be programmed on a dedicated output.

**SLEEP mode** If the charge drops to the threshold value, the board goes into SLEEP mode: automation NOT operational, display off, IN LED flashing every 4 s. Normal operation resumes when the mains supply is restored.

### DETECTION DEVICES

#### ■ CLOSING PHOTOCELLS

The triggering of the photocells during closing, causes the gate to open. An alternative operation can be configured using function P<sub>H</sub> in Advanced programming: the triggering of the photocells stops the gate immediately and opens it when they are released.

If they are engaged when the leaves are stationary, the closing photocells prevent the gate from closing until they are released.

#### ■ OPENING PHOTOCELLS

If the photocells are triggered, the automation is stopped.

#### ■ OPENING/CLOSING PHOTOCELLS

If the photocells are triggered, the automation is stopped.

#### ■ SENSITIVE EDGE SAFETY

If an obstacle is detected during opening or closing, the leaf reverses for 2 s and then the automation stops.

#### ■ OBSTACLE DETECTION BY BOARD OR ENCODER

If an obstacle is detected during opening or closing, the leaf reverses (ANTI-CRUSHING), then the automation stops.

### ACCESSORIES

#### ■ LED

Lights up during opening and stays on as long as the automation remains open. Flashes during closing. It is off when the automation is closed.

#### ■ COURTESY LIGHT

Lights up during movements and remains on for the set time (E1).

#### ■ TRAFFIC LIGHT CONTROL

It lights up when the automation is opening and stays on as long as it remains open.

### OPERATING LOGICS



the STOP command has priority in all the logics and stops the automation.

The CLOSE command always closes the automation.

#### ■ E SEMI-AUTOMATIC

This logic only uses the OPEN command.

OPEN if the automation is closed, causes it to open.

OPEN if the automation is open, causes it to close.

OPEN during opening, stops the gate and the next OPEN command closes it.

OPEN during closing, causes it to reopen.

**The triggering of the photocells** during movement, reverses the gate.

#### ■ EP SEMI-AUTOMATIC STEP-BY-STEP

This logic only uses the OPEN command.

OPEN if the automation is closed, causes it to open.

OPEN if the automation is open, causes it to close.

OPEN during opening or closing, stops the gate and the next OPEN command reverses the direction.

**The triggering of the photocells** during movement, reverses the gate.

#### ■ S AUTOMATIC SAFETY

This logic only uses the OPEN command.

OPEN if the automation is closed, causes it to open. The automation closes automatically after the pause time has elapsed.

OPEN during opening, causes it to close.

OPEN during pause, causes it to close.

OPEN during closing, causes it to reopen.

**The triggering of the closing photocells** during pause, closes the gate - during opening, requests closing, - during closing, causes the gate to reverse and then closes it immediately.

## ■ SR AUTOMATIC SAFETY 2

This logic only uses the OPEN command.

OPEN if the automation is closed, causes it to open. The automation closes automatically after the pause time has elapsed.

OPEN during opening, is ignored.

OPEN during pause, causes it to close.

OPEN during closing, causes it to reopen.

**The triggering of the closing photocells** during pause, reloads the pause time.

## ■ SP AUTOMATIC STEP BY STEP

This logic only uses the OPEN command.

OPEN if the automation is closed, causes it to open. The automation closes automatically after the pause time has elapsed.

OPEN during pause, causes it to close.

OPEN during opening or closing, stops it and the next OPEN command reverses the direction.

**The triggering of the closing photocells** during pause, closes the gate - during opening, requests closing, - during closing, causes the gate to open and then closes it immediately.

## ■ RI AUTOMATIC 1

This logic only uses the OPEN command.

OPEN if the automation is closed, causes it to open. The automation closes automatically after the pause time has elapsed.

OPEN during opening, is ignored.

OPEN during the pause, resets the pause time.

OPEN during closing, causes it to reopen.

**The triggering of the closing photocells** during pause, closes the gate - during opening, requests closing, - during closing, causes the gate to reverse and then closes it immediately.

## ■ R AUTOMATIC

This logic only uses the OPEN command.

OPEN if the automation is closed, causes it to open. The automation closes automatically after the pause time has elapsed.

OPEN during the pause, resets the pause time.

OPEN during opening, is ignored.

OPEN during closing, causes it to reopen.

**The triggering of the closing photocells** during pause, reloads the pause time.

## ■ RP AUTOMATIC STEP-BY-STEP

This logic only uses the OPEN command.

OPEN if the automation is closed, causes it to open. The automation closes automatically after the pause time has elapsed.

OPEN during pause, stops the gate and the next OPEN command closes it.

OPEN during opening, stops the gate and the next OPEN command closes it.

OPEN during closing, causes it to reopen.

**The triggering of the closing photocells** during pause, reloads the pause time.

## ■ RT AUTOMATIC TIMER

This logic only uses the OPEN command.

OPEN if the automation is closed, causes it to open. The automation closes automatically after the pause time has elapsed. If an OPEN input is active at power up, it opens, otherwise it closes.

OPEN during the pause, resets the pause time.

OPEN during opening, is ignored.

OPEN during closing, causes it to reopen.

**The triggering of the closing photocells** during pause, reloads the pause time.

## ■ b SEMI-AUTOMATIC B

This logic uses the OPEN A commands to open and OPEN B (CLOSE) to close. Partial motion is not available.

OPEN if the automation is closed, causes it to open.

OPEN during closing, causes it to reopen.

**If the photocells are triggered** the direction of movement is reversed.

## ■ bC MIXED (B DURING OPENING, C DURING CLOSING)

This logic uses the OPEN A (OPEN) impulse command to open, and maintained OPEN B (CLOSE) to close. Partial motion is not available.



A maintained command must be activated intentionally and the automation must be visible.

OPEN opens the automation.

CLOSE maintained, closes the automation (when opening, a non-maintained CLOSE command stops it).

OPEN during closing, causes it to reopen.

**The triggering of the closing photocells** reverses the direction of movement, the triggering of the opening photocells stops the movement

## ■ C DEAD-MAN

This logic uses the maintained commands OPEN A (OPEN) to open and OPEN B (CLOSE) to close. Partial motion is not available.



A maintained command must be activated intentionally and the automation must be visible.

Maintained OPEN opens the automation.

Maintained CLOSE closes the automation.

**If the photocells are triggered**, movement is stopped.





FAAC S.p.A. Soc. Unipersonale  
Via Calari, 10 - 40069 Zola Predosa BOLOGNA - ITALY  
Tel. +39 051 61724 - Fax +39 051 09 57 820  
[www.faac.it](http://www.faac.it) - [www.faacgroup.com](http://www.faacgroup.com)